	<p style="text-align: center;">MEKRA Lang North America, LLC 101 Tillessen Boulevard Ridgeway, SC 29130</p>	<p>LM 250 Rev # 17 Page 1 of 19</p>
<p style="text-align: center;">Form</p>	<p style="text-align: center;">SUPPLIER AGREEMENT</p>	<p>Approved By: Bhuvesh Dhir Revised By: Manuel Martinez Released By: Renee Tuttle Release Date: 8/13/2024</p>

This Supplier Agreement for Purchase and Sale of Products (the “Agreement”) is made and entered into on [INSERT EFFECTIVE DATE OF AGREEMENT] (“Effective Date”), by and between **MEKRA Lang North America, LLC**, a South Carolina limited liability company and/or (as shown on the signature lines below) **Mekra Lang México S. de R.L. de C.V.**, [INSERT PLACE OF ORGANIZATION AND TYPE OF ENTITY] (individually or collectively, “**MLNA/MLMX**”) and [INSERT LEGAL NAME OF SUPPLIER], a [INSERT PLACE OF ORGANIZATION AND TYPE OF ENTITY] (“**Supplier**”). **MLNA/MLMX** and Supplier are collectively referred to as the “Parties” and each is a “Party.”

1. Object of Contract.

WHEREAS, **MLNA/MLMX** manufactures predominantly vision systems and other parts for manufacturers of vehicles (“**OEMs**”) and their end users (including aftermarket) and wishes to purchase from Supplier certain Products for use in or with **MLNA/MLMX**’s vision systems and other vehicle products; and

WHEREAS, Supplier wishes to provide and sell to **MLNA/MLMX** certain Products for use by **MLNA/MLMX** for the assembly and manufacture of **MLNA/MLMX**’s vision systems and other vehicle products.

NOW THEREFORE, in consideration of the mutual covenants contained herein, and other good and valuable consideration the receipt and sufficiency of which are hereby acknowledged, **MLNA/MLMX** and Supplier agree as follows:

2. Contractual Documents.

(a) This Agreement, along with **MLNA/MLMX**’s Purchase Orders and Releases (as defined below), and the documents listed below, form this Agreement and the terms of these documents are hereby incorporated by reference:

Schedule A: Part Numbers, Description, Raw Material Content/Cost, Price and Production Part Approval Process (“**PPAP**”), Supplier Capacity Confirmation, Commercial Conditions.

Annex 1: [SD 8.4-4 MEKRA Lang North America Quality Requirements](#)

Annex 2: [SD 8.4-3 MEKRA Lang North America Logistics Requirements](#)

Annex 3: [SD 7.4-51 MEKRA Lang North America Packaging and Labeling Requirements](#)

Annex 4: [CP 045 MEKRA Lang North America Code of Conduct](#)

Annexes 1-4 are subject to update by **MLNA/MLMX** from time to time. Supplier is bound by updates and is responsible for regularly checking with **MLNA/MLMX** for updates.

(b) The terms and conditions contained in this Agreement and the Basic Purchase Order Terms exclusively govern and control each of the Parties' respective rights and obligations regarding the purchase and sale of Products, and the Parties' agreement is expressly limited to such terms and conditions. Notwithstanding the foregoing, if any terms and conditions contained in a Purchase Order conflict with any terms and conditions contained in this Master Agreement, the order of precedence is: (a) the Basic Purchase Order Terms of the relevant Purchase Order, (b) this Agreement, and (c) the remaining terms of the relevant Purchase Order.

	<p style="text-align: center;">MEKRA Lang North America, LLC 101 Tillessen Boulevard Ridgeway, SC 29130</p>	<p>LM 250 Rev # 17</p> <p>Page 2 of 19</p>
<p style="text-align: center;">Form</p>	<p style="text-align: center;">SUPPLIER AGREEMENT</p>	<p>Approved By: Bhuvesh Dhir Revised By: Manuel Martinez Released By: Renee Tuttle Release Date: 8/13/2024</p>

(c) Any additional, contrary, or different terms contained in any of Supplier's confirmations, invoices, or other communications, and any other attempt to modify, supersede, supplement, or otherwise alter this Agreement, are deemed rejected by **MLNA/MLMX** and will not modify this Agreement or be binding on the Parties unless such terms have been fully approved in a signed writing by authorized Representatives of both Parties.

3. **Definitions.**

As used herein, the term:

"**Affiliate**" of a Person means any other Person that directly or indirectly, through one or more intermediaries, Controls, is Controlled by, or is under common Control with, such Person.

"**Basic Purchase Order Terms**" means any one or more of the following terms specified by **MLNA/MLMX** in a Purchase Order or Release: (a) Products to be purchased; (b) the quantity of each of Product ordered; (c) the Delivery Date(s) (or range of Delivery Dates); (d) the unit Price for each of Product to be purchased; (e) the billing address; and (f) the Delivery Location(s); in each case, including all terms and conditions attached to, or incorporated into, such Purchase Order. **MLNA/MLMX** may further specify quantities and Delivery Dates in one or more Releases as Basic Purchase Order Terms.

"**Business Day**" means any day other than Saturday, Sunday, or a federal holiday.

"**Claim**" means any claim, action, cause of action, demand, lawsuit, arbitration, inquiry, audit, notice of violation, proceeding, litigation, citation, summons, subpoena, or investigation of any nature, civil, criminal, administrative, regulatory, or otherwise, whether at law, in equity, or otherwise.

"**Contract Year**" shall be the period beginning on the date of Supplier's first delivery of Products in commercial production quantities to **MLNA/MLMX** and ending after the next successive 12 full calendar months, and thereafter each subsequent period of 12 full calendar months.

"**Control**" (and with correlative meanings, the terms "Controlled by" and "under common Control with") means, with respect to any Person, the possession, directly or indirectly, of the power to direct or cause the direction of the management or policies of another Person, whether through the ownership of voting securities, by contract, or otherwise.

"**Customer**" means any OEM, any Tier 1 supplier, or any other purchaser to which **MLNA/MLMX** delivers **MLNA/MLMX**'s products and into which Products hereunder are incorporated or with which Products hereunder are used.

"**Defective Products**" means Products shipped by Supplier to **MLNA/MLMX** pursuant to this Agreement that do not conform to the warranties or other provisions of this Agreement.

"**Delivery Date**" means the delivery date for Products ordered hereunder that is set forth in a Purchase Order.

"**Delivery Location**" means the street address for delivery specified on **Schedule A** or in the applicable Purchase Order.

	<p style="text-align: center;">MEKRA Lang North America, LLC 101 Tillessen Boulevard Ridgeway, SC 29130</p>	<p>LM 250 Rev # 17</p> <p>Page 3 of 19</p>
<p style="text-align: center;">Form</p>	<p style="text-align: center;">SUPPLIER AGREEMENT</p>	<p>Approved By: Bhuvesh Dhir Revised By: Manuel Martinez Released By: Renee Tuttle Release Date: 8/13/2024</p>

"Governmental Authority" means any federal, state, local, or foreign government or political subdivision thereof, or any agency or instrumentality of such government or political subdivision, or any self-regulated organization, or other non-governmental regulatory authority or quasi-governmental authority (to the extent that the rules, regulations, or orders of such organization or authority have the force of Law), or any arbitrator, court, or tribunal of competent jurisdiction.

"Governmental Order" means any order, writ, judgment, injunction, decree, stipulation, award, or determination entered by or with any Governmental Authority.

"Intellectual Property Rights" means all forms of intellectual property rights in any country or region, including, but not limited to, patents, copyright, trademarks, service marks, trade names, logos, copyrights, rights of authorship, inventions, mask work rights, moral rights, rights of inventorship, trade secrets and Know-how, and all rights, interests, and protections that are associated with, equivalent or similar to, or required for the exercise of, any of the foregoing, however arising, in each case whether registered or unregistered and including all registrations and applications for, and renewals or extensions of, such rights or forms of protection pursuant to the Laws of any jurisdiction throughout in any part of the world.

"Know-how" means all confidential knowledge or business information of any nature or form, including, but not limited to, research and development data and records, inventions, discoveries, ideas, processes, formulae, drawings, specifications, descriptions, methods, routines, manuals, instructions, production data, experiences and other technical or commercial know-how as well as all books and records in whatever form in relation to the foregoing.

"Law" means any statute, law, ordinance, regulation, rule, code, constitution, treaty, common law, Governmental Order, or other requirement or rule of law of any Governmental Authority.

"Losses" mean any and all losses, damages, liabilities, deficiencies, claims, actions, judgments, settlements, interest, awards, penalties, fines, costs, or expenses of whatever kind, including attorneys' fees, fees, and the costs of enforcing any right to indemnification under this Agreement and the cost of pursuing any insurance providers.

"Person" means any individual, partnership, corporation, trust, limited liability entity, unincorporated organization, association, Governmental Authority, or any other entity.

"Product(s)" shall mean the production goods, products, works and services manufactured and/or processed by Supplier as described on **Schedule A**, including without limitation all production and service parts, components, assemblies, accessories, raw materials, portions, items, repairs, replacements and substitutions thereof.

"Purchase Order" means any order for the purchase of Products issued by **MLNA/MLMX** to Supplier, including **MLNA/MLMX's** Releases.

"Release" means any document that describes the required quantity of Product and Delivery Date(s) (e.g. releases, demands, scheduling orders or agreements).

	<p style="text-align: center;">MEKRA Lang North America, LLC 101 Tillessen Boulevard Ridgeway, SC 29130</p>	<p>LM 250 Rev # 17</p> <p>Page 4 of 19</p>
<p style="text-align: center;">Form</p>	<p style="text-align: center;">SUPPLIER AGREEMENT</p>	<p>Approved By: Bhuvesh Dhir Revised By: Manuel Martinez Released By: Renee Tuttle Release Date: 8/13/2024</p>

"Representatives" means a Party's Affiliates, and each of their respective employees, agents, subcontractors, officers, directors, partners, shareholders, attorneys, third-party advisors, successors, and permitted assigns.

"Taxes" means any and all sales, use, gross receipts, environmental, ad valorem, or excise tax or any other similar taxes, fees, duties, or charges of any kind imposed by any Governmental Authority on any amounts payable by **MLNA/MLMX** under this Agreement; exclusive, however, of any taxes, assessments, or other levies imposed on Supplier's income or capital (including leased or purchased property, equipment, or software), any franchise taxes, any taxes in lieu of net income taxes, and any other direct taxes imposed on Supplier.

4. Purchase and Sale of Products.

- (a) Pursuant to Purchase Orders issued by **MLNA/MLMX**, Supplier shall sell and deliver to **MLNA/MLMX**, and **MLNA/MLMX** shall purchase from Supplier, Products specified in Purchase Orders. Such purchases and sales shall be for Products and Prices set forth on **Schedule A**. Any Affiliate of **MLNA/MLMX** shall also be entitled to issue Purchase Orders and purchase Products from Supplier under the terms of this Agreement. Only the specific **MLNA/MLMX** Party issuing a Purchase Order will be liable to Supplier for obligations in connection with a Purchase Order. Neither **MLNA** or **MLMX** or any Affiliate of either of them will be liable to Supplier for any obligations of any other **MLNA/MLMX** Party or Affiliate.
- (b) During the term hereof, **MLNA/MLMX** may, but shall not be required to, provide Supplier with estimates or forecasts of **MLNA/MLMX**'s requirements for Products from Supplier. Any forecasts or estimates are for information purposes only and may be modified by **MLNA/MLMX** at any time and in its sole discretion. Any product quantities cited in or pursuant to this Agreement, except for quantities cited in a Purchase Order as firm, are preliminary and non-binding only. **MLNA/MLMX** makes no representation, warranty or agreement as to the quantity of products that it will purchase from Supplier, if any, or that **MLNA/MLMX** will buy Products exclusively from Supplier.
- (c) **MLNA/MLMX** shall issue Purchase Orders to Supplier and Supplier shall confirm to **MLNA/MLMX** the receipt of each Purchase Order issued hereunder (each, a "**Confirmation**") within [NUMBER] Business Days following Supplier's receipt thereof. Each Confirmation must reference **MLNA/MLMX**'s Purchase Order number and confirm acceptance of the Purchase Order unless Supplier timely advises **MLNA/MLMX** that Supplier is unwilling to accept any terms or conditions in the applicable Purchase Order that conflict with the terms and conditions of this Agreement. If Supplier fails to issue a Confirmation within the time set forth above or otherwise commences performance under such Purchase Order, Supplier will be deemed to have accepted the Purchase Order. **MLNA/MLMX** may withdraw any Purchase Order prior to Supplier's acceptance (or deemed acceptance) thereof.
- (d) **MLNA/MLMX** may, in its sole discretion, on notice to Supplier, without liability or penalty, terminate all or any part of a Purchase Order with or without cause effective immediately or otherwise as specified in such notice. Upon any such termination, Supplier shall immediately cease work and purchasing materials relating to fulfilling the Purchase Order, and deliver to **MLNA/MLMX** on request all or any portion of Products under the relevant Purchase Order at the Prices.
- (e) **MLNA/MLMX** may, on notice to Supplier, request changes to a Purchase Order. On or before the second Business Day after receiving the request, Supplier shall submit to **MLNA/MLMX** its good faith

	<p style="text-align: center;">MEKRA Lang North America, LLC 101 Tillessen Boulevard Ridgeway, SC 29130</p>	<p>LM 250 Rev # 17 Page 5 of 19</p>
<p style="text-align: center;">Form</p>	<p style="text-align: center;">SUPPLIER AGREEMENT</p>	<p>Approved By: Bhuvesh Dhir Revised By: Manuel Martinez Released By: Renee Tuttle Release Date: 8/13/2024</p>

description of the impact of such changes on the Basic Purchase Order Terms. **MLNA/MLMX** may then submit an amended Purchase Order reflecting all **MLNA/MLMX**-accepted changes.

5. Price and Payment Terms.

- a) **MLNA/MLMX** reserves the right to withhold payment for Defective Products until such time as Supplier has fulfilled all of its obligations.
- b) Payment for Products shall not constitute acceptance of Products, and all Products shall be subject to **MLNA/MLMX**'s inspection and rejection by **MLNA/MLMX** as well as other rights of **MLNA/MLMX** under this Agreement and applicable Law.
- c) The prices in **Schedule A ("Prices")** are firm for the term of this Agreement and any extensions thereof. All Prices include, and Supplier is solely responsible for, all costs and expenses relating to packing, crating, boxing, transporting, loading and unloading, customs, Taxes, tariffs and duties, insurance, and any other similar financial contributions or obligations relating to the production, manufacture, sale, and delivery of Products. Prices are not subject to increase for any reason, including changes in market conditions, increases in raw material, component, labor, or overhead costs, or because of labor disruptions, changes in program timing or length, or fluctuations in production volumes.
- d) **MLNA/MLMX** and Supplier may meet as needed to discuss possible adjustments of Prices. Any agreement to adjust Prices shall be based upon documented and justifiable grounds and subject to **MLNA/MLMX**'s agreement in its sole discretion. The agreed upon adjusted Prices shall be effective for all Products sold to **MLNA/MLMX** for the subsequent Contract Year, or as mutually agreed upon in writing by the Parties.
- e) **Invoicing and Payment.**
Supplier shall issue invoices to **MLNA/MLMX** for all Products delivered. The payment terms shall be net 90 calendar days' after the later of timely delivery of Products and receipt of a correct invoice.
 - (i) All invoices for the amounts stated as payable by **MLNA/MLMX** to Supplier shall be in such form, and accompanied by such information, as may reasonably be requested by **MLNA/MLMX** from time to time in order to verify the invoice amounts. **MLNA/MLMX** will not be obligated to pay any amount not properly invoiced within 90 days following delivery.
 - (ii) **MLNA/MLMX** shall pay only the undisputed portion of an invoice and shall notify Supplier of the amount in dispute and the basis for the dispute. Supplier shall continue performing its obligations under this Agreement during any such dispute.
 - (iii) Payment of invoices will not be deemed acceptance of Products or waiver of any rights of **MLNA/MLMX** under this Agreement or applicable Law.
- f) **Requirement to Remain Competitive.** Supplier shall remain competitive with respect to Products in terms of pricing, quality, performance, technology, and delivery during the term of this Agreement and any extension(s) thereof. Prices to be paid for Products shall not at any time be higher than the price paid by any of Supplier's other customers for the same or similar products. **MLNA/MLMX** may request that Supplier certify that it is not selling such same or similar products to any of Supplier's other customers at

	<p style="text-align: center;">MEKRA Lang North America, LLC 101 Tillessen Boulevard Ridgeway, SC 29130</p>	<p>LM 250 Rev # 17</p> <p>Page 6 of 19</p>
<p style="text-align: center;">Form</p>	<p style="text-align: center;">SUPPLIER AGREEMENT</p>	<p>Approved By: Bhuvesh Dhir Revised By: Manuel Martinez Released By: Renee Tuttle Release Date: 8/13/2024</p>

a price that is lower than **MLNA/MLMX** is paying for any Product. Should another supplier demonstrate technology which yields similar goods of equal or better quality or performance or at a lower price to **MLNA/MLMX** during the course of this Agreement, **MLNA/MLMX** may notify Supplier in writing of such competitive product(s) and Supplier shall have 90 days after receipt of notice to make Products competitive and available for delivery. If Supplier is unable or unwilling to make Products competitive within such period without violating the proprietary rights of any other party, **MLNA/MLMX** may immediately terminate this Agreement without further liability to Supplier.

6. Product Changes.

- (a) Supplier shall not make any changes to (a) the specifications of Products or any portion or component of Products; (b) the raw materials, production processes, procedures, or equipment used to manufacture Products; (c) the facility or facilities at which Products are manufactured; without **MLNA/MLMX**'s prior written consent.

- (b) Either Party may from time to time propose a change of the specifications for Products. If the Parties agree to change the specifications, the Price of the affected Product shall be adjusted in proportion to the resulting change in Supplier's costs. If a change results in nonrecurring expenses for Supplier (e.g., tooling amortization), Supplier shall agree to reduce Prices upon recovery of those expenses.
 - (i) For Supplier initiated changes, Supplier shall provide suggested implementation date, new product specifications, highlight of changes from current product design, reasons for making the product change and all applicable cost impacts, if any; and,
 - (ii) Supplier shall provide **MLNA/MLMX** with the information in subsection (i) along with any other reasonably requested documentation within 30 days of its initial written notice of proposed specification changes.

7. Inspection.

- (a) **MLNA/MLMX** and its Customer shall have the right, but not the obligation, to inspect Products at any time during normal business hours at Supplier's manufacturing or storage facilities. After receipt of Products, **MLNA/MLMX**'s shall also have the right, but not the obligation, to inspect each delivery. Inspection or failure to inspect shall not be deemed a waiver of any of **MLNA/MLMX**'s rights.

- (b) Upon two Business Days' notice, and without advance notice in urgent cases, **MLNA/MLMX** shall be entitled to access all pertinent information for the purpose of auditing Supplier's invoices, Supplier shall preserve these documents for a period of 3 years after receipt of the final payment under this Agreement. In addition, and upon two Business Days' notice and without notice in urgent cases, **MLNA/MLMX** shall be entitled to have access to Supplier's premises during normal business hours and without interfering with Supplier's business in order to inspect all pertinent information regarding Supplier's manufacturing process, including, but not limited to, all work, materials, inventories, parts, tools, fixtures, gages and models and other items provided under **Schedule A**. Supplier shall segregate its records and otherwise cooperate with **MLNA/MLMX** to facilitate the audit or inspection.

8. Shipment and Delivery.

	<p style="text-align: center;">MEKRA Lang North America, LLC 101 Tillessen Boulevard Ridgeway, SC 29130</p>	<p>LM 250 Rev # 17 Page 7 of 19</p>
<p style="text-align: center;">Form</p>	<p style="text-align: center;">SUPPLIER AGREEMENT</p>	<p>Approved By: Bhuvesh Dhir Revised By: Manuel Martinez Released By: Renee Tuttle Release Date: 8/13/2024</p>

- (a) Time, quantity, and delivery to the Delivery Location are of the essence under this Agreement. Supplier shall assemble, pack, mark, and ship Products strictly in the quantities, by the methods, to the Delivery Locations, and by the Delivery Dates, specified in or accordance with this Agreement. Delivery times will be measured to the time that Goods are actually received at the Delivery Location.
- (b) Supplier shall utilize forecast information submitted by **MLNA/MLMX** to ensure an adequate supply of Products within typical market fluctuations. Supplier shall maintain awareness of market conditions and advise **MLNA/MLMX** immediately upon receiving knowledge of a possible interruption in supply chain or potential failure to meet **MLNA/MLMX**'s forecasts or Releases. Any such "Short-Notice" notifications received less than 30 days in advance will be not accepted by **MLNA/MLMX**. Supplier will not condition the delivery of material, and will not use it as an argument to obtain an advantage over **MLNA/MLMX**, all costs generated by those actions shall be directly transfer to the supplier.
- (c) Supplier shall assure that such quantities will be sufficient to meet **MLNA/MLMX**'s orders as projected hereunder by **MLNA/MLMX**. The Supplier shall maintain a safety stock of finished goods that matches the fabrication authorization per release orders, and maintain a safety stock of raw material that matches the raw material authorization per release orders.
- (d) If, for any reason, Supplier fails to make delivery of Products without the agreed quality level and quantity in the time specified in the Releases, **MLNA/MLMX** may, at its option, demand for approve and revise delivery schedule from Supplier, request corrective actions from Supplier, like shipment via air or expedited routing, at Supplier's expense or just proceed to arrange the corrective actions with Mekra Lang resources and the costs will be immediately charged to Supplier or deducted from invoicing, in case of repetitive Delivery or Quality Issues **MLNA/MLMX** will terminate the order without any compensation to Supplier.
- (e) If Products are delivered after the Delivery Date, **MLNA/MLMX** may, at its sole discretion, hold Supplier responsible for Losses associated with the late delivery. These Losses may include, but are not limited to, expediting costs of component and finished goods, line downtime, overtime, or administrative costs. In the event that a late delivery affects delivery of **MLNA/MLMX**'s products to a Customer, Supplier shall be responsible for any Losses charged to **MLNA/MLMX** because of said late delivery. These Losses will be immediately charged to Supplier or deducted from invoicing.
- (f) If Supplier desires to move its shipping location with **MLNA/MLMX**'s approval and the move will result in an increase of the aggregate freight costs for **MLNA/MLMX**. Supplier shall reduce Prices to offset the additional freight costs, and seek **MLNA/MLMX**'s approval at least 60 days in advance.
- (g) Title to Goods shipped passes to **MLNA/MLMX** upon delivery of the Goods to the Delivery Location. Title will transfer to **MLNA/MLMX** even if Supplier has not been paid for such Goods. Notwithstanding any agreement between **MLNA/MLMX** and Supplier concerning transfer of title or responsibility for shipping costs, risk of loss to Goods passes to **MLNA/MLMX** upon receipt by **MLNA/MLMX** at the Delivery Location, and Supplier will bear all risk of loss or damage regarding Goods until **MLNA/MLMX**'s receipt of such Goods in accordance with the terms hereof.

	<p style="text-align: center;">MEKRA Lang North America, LLC 101 Tillessen Boulevard Ridgeway, SC 29130</p>	<p>LM 250 Rev # 17</p> <p>Page 8 of 19</p>
<p style="text-align: center;">Form</p>	<p style="text-align: center;">SUPPLIER AGREEMENT</p>	<p>Approved By: Bhuvesh Dhir Revised By: Manuel Martinez Released By: Renee Tuttle Release Date: 8/13/2024</p>

9. Packing, Labeling, Shipping and Documentation.

- (a) All Products shall be properly packaged to prevent damage or deterioration and to obtain the lowest transportation rates. All packaging and labeling shall be conducted in accordance with **MLNA/MLMX's** Supplier Packaging and Labeling Requirements (Annex 3).
- (b) All Products shall be properly identified as to country of origin, and all packaging, labeling and documentation in connection with Products shall comply with applicable Law. In addition to its other obligations under this Agreement Supplier shall reimburse **MLNA/MLMX** for any Losses arising out of the failure of Products to be properly marked or the failure of such documentation to comply with all applicable Law, including, but not limited to, (i) all costs incurred in bringing Products or the documentation into compliance with Law, (ii) all freight costs for additional materials to cover production or Customer requirements, (iii) any fines, penalties or forfeitures levied by any Government Authority or Customer, and (iv) any legal expenses and fees.
- (c) Supplier shall promptly provide **MLNA/MLMX** with an accurate and complete USMCA Certificate of Origin and/or any other applicable country of origin certificate or declaration of origin certificate along with supporting documentation and an accurate and complete International Material Data System (IMDS) Certificate in accordance with applicable Law prior to the first delivery of any Products. In addition to its other obligations under this Agreement, Supplier shall reimburse **MLNA/MLMX** and/or Customers for any Losses resulting directly or indirectly from the Supplier's delay in furnishing such certificates to **MLNA/MLMX** and from incorrect information therein furnished by the Supplier.
- (d) Supplier shall comply with **MLNA/MLMX** 's labeling information (for series & project stage), label should be on at least two sides of the container, on adjacent corners in conformance to industry labeling practices. Suppliers are encouraged to develop bar code labeling techniques for product shipments. The print on the identification labels should be legible from 10 feet. Old labels should be removed from the containers. Containers shall be clearly identified with part numbers, description, supplier name, tracking number, and Purchase Order and/or Release number, OEM.

10. Product Warranties and Remedies.

- (a) Supplier warrants that:
 - (i) all Products sold and delivered hereunder shall be in accordance with samples submitted and agreed specifications.
 - (ii) Products shall be of merchantable quality, free from defects in materials and workmanship, and safe and fit for their intended use.
 - (iii) no claim, lien, or action exists or is threatened against Supplier that would interfere with **MLNA/MLMX's** use or sale of Products.
 - (iv) Products do not infringe any third-party Intellectual Property Rights, unless the infringement is based on designs furnished by **MLNA/MLMX**.
 - (v) **MLNA/MLMX** will receive good and valid title to Products, free and clear of all encumbrances and liens of any kind; and
 - (vi) Products are new and do not contain used or reconditioned parts.

	<p style="text-align: center;">MEKRA Lang North America, LLC 101 Tillessen Boulevard Ridgeway, SC 29130</p>	<p>LM 250 Rev # 17</p> <p>Page 9 of 19</p>
<p style="text-align: center;">Form</p>	<p style="text-align: center;">SUPPLIER AGREEMENT</p>	<p>Approved By: Bhuvesh Dhir Revised By: Manuel Martinez Released By: Renee Tuttle Release Date: 8/13/2024</p>

Supplier shall be responsible for any Losses (e.g., costs for sorting, actual defects, replacement, and associated administrative costs) relevant to Products prior to shipment to Customer. **MLNA/MLMX** may immediately direct debit account charges for product quality or delivery issues. Supplier further represents that it is able to maintain stabilized control of its manufacturing process and that it will maintain comprehensive statistical documentation to validate its processes.

- (b) Supplier is responsible for quality and field performance of Products provided to **MLNA/MLMX**. In the event of poor Product quality or Product failure, Supplier shall be responsible for costs associated with the insufficient quality or performance of the Product. Examples of related costs include, but are not limited to, replacement part cost, shipping & handling, labor costs of troubleshooting & repair, and administrative costs.
- (c) Products are intended to be used in various heavy vehicle mirror assemblies to be installed on trucks and **MLNA/MLMX** is under obligation to the OEM for a three year or 350,000 miles in-service warranty, whichever comes first. Therefore, Supplier warrants that Products will be free of defects in material and workmanship for the period of three years or 350,000 miles in-service use (whichever comes first) by the end-user of the commercial vehicle. The times set forth for delivery and the quality of Products, therefore, are of the essence. If delivery is delayed or Products do not meet the three year or 350,000 miles in-service warranty (whichever comes first) set forth above, Supplier shall be liable and shall reimburse **MLNA/MLMX** within 20 Business Days after written demand for its Losses, including, but not limited to, repair and/or replacement of Products.
- (e) If Products do not comply with the warranties in this Agreement, in addition to other remedies available at Law or in this Agreement, Supplier shall, at **MLNA/MLMX**'s discretion:
 - (i) repair or replace such Defective Products; or
 - (ii) credit or refund the Price of such Defective Products plus any inspection, test, and transportation charges paid by **MLNA/MLMX**, less any applicable discounts, rebates, or credits.
- (f) If **MLNA/MLMX**, any Customers, Supplier or any Governmental Authority determines that any Products sold to **MLNA/MLMX** are defective and a recall campaign is necessary, either Party may implement such recall campaign. **MLNA/MLMX** may return Defective Products to Supplier or destroy such Products, as determined by **MLNA/MLMX**, at Supplier's sole cost and risk, in addition to **MLNA/MLMX**'s remedies specified above for Defective Products. The foregoing will apply even if the product warranties applicable to the Products have expired. Supplier is liable for all of **MLNA/MLMX**'s costs associated with any recall campaign if such recall campaign is based on a reasonable determination that either: (a) Products fail to conform to either the warranties under this Agreement or applicable Law; or (b) the basis for the recall arose from Supplier's negligence or willful misconduct.

11. **Term and Termination.**

- (a) The term of this Agreement commences on the Effective Date and continues until terminated as provided below (the "**Term**"). The Term will automatically renew for additional successive Contract Years unless and until **MLNA/MLMX** provides notice of nonrenewal at least 30 days before the end of the then-current Term, or unless and until earlier terminated as provided under this Agreement

	<p style="text-align: center;">MEKRA Lang North America, LLC 101 Tillessen Boulevard Ridgeway, SC 29130</p>	<p>LM 250 Rev # 17</p> <p>Page 10 of 19</p>
<p style="text-align: center;">Form</p>	<p style="text-align: center;">SUPPLIER AGREEMENT</p>	<p>Approved By: Bhuvesh Dhir Revised By: Manuel Martinez Released By: Renee Tuttle Release Date: 8/13/2024</p>

- (b) **MLNA/MLMX** may terminate this Agreement (including all Purchase Orders), on notice to Supplier:
- (i) if Supplier repudiates or threatens to repudiate any of its obligations under this Agreement;
 - (ii) if Supplier is in breach of, or threatens to breach, any representation, warranty, or covenant of Supplier under this Agreement and either the breach cannot be cured or, if the breach can be cured, it is not cured by Supplier within a commercially reasonable period of time under the circumstances, in no case exceeding 30 days following Supplier's receipt of notice of such breach;
 - (iii) notwithstanding the preceding provision, if Supplier fails to, or threatens to fail to, timely deliver Products conforming to the requirements of, and otherwise in accordance with, the terms and conditions of this Agreement;
 - (iv) if Supplier becomes insolvent or is generally unable to pay, or fails to pay, its debts as they become due; files or has filed against it, a petition for voluntary or involuntary bankruptcy or otherwise becomes subject, voluntarily or involuntarily, to any proceeding under any domestic or foreign bankruptcy or insolvency Law; seeks reorganization, arrangement, adjustment, winding-up, liquidation, dissolution, composition, or other relief with respect to it or its debts; makes or seeks to make a general assignment for the benefit of its creditors; or applies for or has a receiver, trustee, custodian, or similar agent appointed by order of any court of competent jurisdiction to take charge of or sell any material portion of its property or business;
 - (v) if Supplier fails to provide **MLNA/MLMX**, within a commercially reasonable time after **MLNA/MLMX**'s request (but in no case exceeding 10 days after such request) with adequate and reasonable assurance of Supplier's financial and operational capability to timely perform Supplier's obligations under this Agreement;
 - (vi) in the event of a Force Majeure Event affecting the Supplier's performance of this Agreement for more than 10 Business Days;
 - (vii) if, without obtaining **MLNA/MLMX**'s prior written consent, (x) Supplier sells, leases, or exchanges a material portion of Supplier's assets, (y) Supplier merges or consolidates with or into another Person, or (z) a change in Control of Supplier occurs; or
 - (viii) at **MLNA/MLMX**'s option, at any time, and for any reason.

Any termination under this 0 is effective on Supplier's receipt of **MLNA/MLMX**'s notice of termination or any later date set out in the notice.

- (c) Supplier may terminate this Agreement (including all Purchase Orders) on notice to **MLNA/MLMX** if **MLNA/MLMX** is in material breach of any representation, warranty, or covenant of **MLNA/MLMX** under this Agreement, and either the breach cannot be cured or, if the breach can be cured, it is not cured by **MLNA/MLMX** within a commercially reasonable period of time (in no case exceeding 30 days) after **MLNA/MLMX**'s receipt of notice of such breach. Any termination under this 0 is effective on **MLNA/MLMX**'s receipt of Supplier's notice of termination or any later date set out in the notice.
- (d) Effect of Expiration or Termination.
- (i) Unless the terminating Party directs otherwise, any termination automatically terminates all Purchase Orders.
 - (ii) Upon the expiration or earlier termination of this Agreement, Supplier shall promptly return to **MLNA/MLMX** all documents and tangible materials (and any copies) containing, reflecting,

	<p style="text-align: center;">MEKRA Lang North America, LLC 101 Tillessen Boulevard Ridgeway, SC 29130</p>	<p>LM 250 Rev # 17</p> <p>Page 11 of 19</p>
<p style="text-align: center;">Form</p>	<p style="text-align: center;">SUPPLIER AGREEMENT</p>	<p>Approved By: Bhuvesh Dhir Revised By: Manuel Martinez Released By: Renee Tuttle Release Date: 8/13/2024</p>

incorporating, or based on **MLNA/MLMX's** Confidential Information; and permanently erase all of **MLNA/MLMX's** Confidential Information from its computer systems

- (iii) The Party terminating this Agreement, or in the case of the expiration of this Agreement, each Party, shall not be liable to the other Party for any damage of any kind (whether direct or indirect) incurred by the other Party by reason of the expiration or earlier termination of this Agreement. Termination of this Agreement will not constitute a waiver of any of the terminating Party's rights or remedies under this Agreement, at law, in equity, or otherwise.
- (iv) If requested in writing by **MLNA/MLMX**, Supplier shall, upon expiration of the Agreement, cooperate with **MLNA/MLMX** in the orderly and smooth transition of business to a new Supplier. In this event, a reasonable transition time shall be determined by **MLNA/MLMX**. This shall include, but not be limited to:
 - A. The continued supply of quality Products and parts delivered on time to **MLNA/MLMX** facilities from the date of **MLNA/MLMX's** request to the expiration date.
 - B. The production of a quantity of Product, to be determined by **MLNA/MLMX**, to ensure continuity of supply while **MLNA/MLMX**-owned tooling and assets are being transferred to a new Supplier.
 - C. Material handling and administrative support in moving **MLNA/MLMX**-owned tooling and other assets out of Supplier's facility.

12. Confidentiality and Exchange of Financial Information.

- (a) Supplier agrees to maintain the confidentiality of all proprietary information as set forth and agreed to in any separate confidentiality agreement entered into between the Parties. In addition, from time to time during the Term, **MLNA/MLMX** may disclose or make available to Supplier information about **MLNA/MLMX's** business affairs, goods and services, forecasts, confidential information, and materials comprising or relating to Intellectual Property Rights, third-party confidential information, and other sensitive or proprietary information, such information, as well as the terms of this Agreement, whether orally or in written, electronic, or other form or media, and whether or not marked, designated, or otherwise identified as "confidential" constitutes "Confidential Information" hereunder. Confidential Information excludes information that at the time of disclosure and as established by documentary evidence:
 - (i) is or becomes generally available to and known by the public other than as a result of, directly or indirectly, any breach of this Section by Supplier or any of its Representatives;
 - (ii) is or becomes available to Supplier on a non-confidential basis from a third-party source, provided that such third party is not and was not prohibited from disclosing such Confidential Information;
 - (iii) was known by or in the possession of Supplier or its Representatives before being disclosed by or on behalf of **MLNA/MLMX**;
 - (iv) was or is independently developed by Supplier without reference to or use of, in whole or in part, any of **MLNA/MLMX's** Confidential Information; or
 - (v) is required to be disclosed pursuant to applicable Law.
- (b) Supplier shall, for 3 years from disclosure of such Confidential Information:
 - (i) protect and safeguard the confidentiality of **MLNA/MLMX's** Confidential Information with at least the same degree of care as Supplier would protect its own Confidential Information, but in no event with less than a commercially reasonable degree of care;

	<p style="text-align: center;">MEKRA Lang North America, LLC 101 Tillessen Boulevard Ridgeway, SC 29130</p>	<p>LM 250 Rev # 17</p> <p>Page 12 of 19</p>
<p style="text-align: center;">Form</p>	<p style="text-align: center;">SUPPLIER AGREEMENT</p>	<p>Approved By: Bhuvesh Dhir Revised By: Manuel Martinez Released By: Renee Tuttle Release Date: 8/13/2024</p>

- (ii) not use **MLNA/MLMX's** Confidential Information, or permit it to be accessed or used, for any purpose other than to exercise its rights or perform its obligations under this Agreement; and
- (iii) not disclose any such Confidential Information to any Person, except to Supplier's Representatives who need to know the Confidential Information to assist Supplier, or act on its behalf, to exercise its rights or perform its obligations under this Agreement.

Supplier shall be responsible for any breach of this Section caused by any of its Representatives. The provisions of this Section shall survive termination or expiration of this Agreement for any reason for a period of 3 years after such termination or expiration. At any time during or after the Term, at **MLNA/MLMX's** written request, Supplier and its Representatives shall, promptly return all Confidential Information and copies thereof that it has received under this Agreement.

13. Intellectual Property Rights.

- (a) All Intellectual Property Rights developed and documented by **MLNA/MLMX** or Supplier, jointly or separately, within the scope of this Agreement, or related to Products, shall be the property of **MLNA/MLMX**. Supplier grants and assigns **MLNA/MLMX** all of Supplier's such Intellectual Property Rights. Supplier shall perform whatever actions are reasonably required or requested by **MLNA/MLMX** in order to transfer ownership of same to **MLNA/MLMX** or to provide evidence of **MLNA/MLMX's** ownership thereof.
- (b) All Intellectual Property Rights developed by or on behalf of Supplier outside the scope of this Agreement, or not related to Products shall remain the sole property of Supplier.
- (c) Each Party hereto shall be free to independently commercialize their respective Intellectual Property Rights in any conceivable way without the consent of the other Party hereto.
- (d) Unless otherwise expressly agreed, neither Party may not use the other Party's Intellectual Property Rights to include, without limitation, the other Party's trademarks, trade names or logos.

14. Insurance.

- (a) Without limiting Supplier's indemnification obligations under this Agreement, during the Term and for a period of [TIME PERIOD] thereafter], Supplier shall maintain in full force and effect commercial general liability insurance coverage with a policy limit for each occurrence and in the aggregate of at least Twenty Million Dollars (\$20,000,000), consisting of at least Five Million Dollars (\$5,000,000) in primary coverage and the remaining Fifteen Million Dollars (\$15,000,000) in an umbrella form for excess liability coverage, including bodily injury and property damage and products and completed operations, which policies will include contractual liability coverage insuring the activities of Supplier under this Agreement. Furthermore, Supplier shall carry and maintain automobile, worker's compensation, employer's liability and occupational disease insurance with coverage in a form satisfactory to **MLNA/MLMX**.
- (b) Supplier shall ensure that all required insurance policies:
 - (i) are issued by insurance companies reasonably acceptable to **MLNA/MLMX**;
 - (ii) provide that such insurance carriers give **MLNA/MLMX** at least 30 days' prior notice of cancellation or non-renewal of policy coverage, provided that, prior to such cancellation, Supplier has new insurance policies in place that meet the requirements of this Section;
 - (iii) provide that such insurance be primary insurance and any similar insurance in the name of and/or for the benefit of **MLNA/MLMX** shall be excess and non-contributory;

	<p style="text-align: center;">MEKRA Lang North America, LLC 101 Tillessen Boulevard Ridgeway, SC 29130</p>	<p>LM 250 Rev # 17</p> <p>Page 13 of 19</p>
<p style="text-align: center;">Form</p>	<p style="text-align: center;">SUPPLIER AGREEMENT</p>	<p>Approved By: Bhuvesh Dhir Revised By: Manuel Martinez Released By: Renee Tuttle Release Date: 8/13/2024</p>

- (iv) name **MLNA/MLMX** and **MLNA/MLMX's** Affiliates, including, in each case, all successors and permitted assigns, as additional insureds; and
- (v) waive any right of subrogation of the insurers against **MLNA/MLMX** or any of its Affiliates.

(c) Supplier shall provide **MLNA/MLMX** with copies of the certificates of insurance and policy endorsements for all required insurance coverage, and shall not do anything to invalidate such insurance. This Section shall not be construed in any manner as waiving, restricting, or limiting the liability of either Party for any obligations imposed under this Agreement (including but not limited to, any provisions requiring a party hereto to indemnify, defend, and hold the other harmless under this Agreement).

15. Indemnification.

- a) Supplier (as "Indemnifying Party") shall indemnify, defend, and hold harmless **MLNA/MLMX** and its Affiliates and Customers and its and their Representatives, successors, and assigns (collectively, "Indemnified Party") against any and all Losses relating to any Claim of a third party or Party alleging:
 - (i) breach or non-fulfillment of any representation, warranty, or covenant under this Agreement by Indemnifying Party or Indemnifying Party's Representative;
 - (ii) any negligent or more culpable act or omission of Indemnifying Party or its Representative (including any recklessness or willful misconduct) in connection with the performance of its obligations under this Agreement;
 - (iv) any bodily injury, death of any Person, or damage to real or tangible personal property caused by the acts or omissions of Indemnifying Party or its Representative or Products;
 - (v) any failure by Indemnifying Party or its Representative to comply with any applicable Law where Products are sold or delivered or where Customer products are sold or delivered;
 - (vi) any recall of Products;
 - (vii) Products infringe any third-party Intellectual Property Rights, unless the infringement is based on designs furnished by **MLNA/MLMX**; or
 - (viii) Losses to any property (including, without limitation, **MLNA/MLMX's** property) or any spill, discharge or emission of hazardous wastes or substances which relate to, in whole or in part, any defect of Products or any failure of Supplier to warn or any improper handling, operating or installation instructions or other act or omission of Supplier with respect to Products, or the performance by Supplier of any services for **MLNA/MLMX**, whether on the premises of **MLNA/MLMX**, Supplier or any third party.

- b) In addition and not in limitation of the foregoing, Supplier shall pay interest at any annual rate of ten percent (10%) to **MLNA/MLMX** on all amounts owed under this Section. **MLNA/MLMX** may at its option participate in the defense of any Claim with **MLNA/MLMX's** own attorney at Supplier's expense.

16. Force Majeure.

- (a) No Party shall be liable or responsible to the other Party, or be deemed to have defaulted under or breached this Agreement, for any failure or delay in fulfilling or performing any term of this Agreement (except for any obligations to make payments to the other Party hereunder), when and to the extent such party's (the "Impacted Party") failure or delay is caused by or results from the following force majeure events ("**Force Majeure Event(s)**"): (a) acts of God; (b) flood, fire, earthquake, epidemics, pandemics or explosion; (c) war, invasion, hostilities (whether war is declared or not), terrorist threats or acts, riot or other civil unrest;

	<p style="text-align: center;">MEKRA Lang North America, LLC 101 Tillessen Boulevard Ridgeway, SC 29130</p>	<p>LM 250 Rev # 17</p> <p>Page 14 of 19</p>
<p style="text-align: center;">Form</p>	<p style="text-align: center;">SUPPLIER AGREEMENT</p>	<p>Approved By: Bhuvesh Dhir Revised By: Manuel Martinez Released By: Renee Tuttle Release Date: 8/13/2024</p>

(d) government order, law, or action; (e) embargoes or blockades in effect after the date of this Agreement; and (f) other similar events beyond the control of the Impacted Party. Supplier's financial inability to perform, changes in cost or availability of materials, components, or services, market conditions or supplier actions, strikes or work stoppages, or labor or contract disputes will not excuse performance by Supplier under this Section.

(b) The Impacted Party shall give notice within 2 Business Days of the Force Majeure Event to the other Party, stating the period of time the occurrence is expected to continue. The Impacted Party shall use diligent efforts to end the failure or delay and ensure the effects of such Force Majeure Event are minimized. The Impacted Party shall resume the performance of its obligations as soon as reasonably practicable after the removal of the cause. In the event that the Impacted Party's failure or delay remains uncured for a period of 10 Business Days, **MLNA/MLMX** may thereafter terminate this Agreement upon written notice.

(c) In addition to its other rights under this Agreement or the applicable Law, during any Force Majeure Event with Supplier as the Impacted Party, **MLNA/MLMX** may, at its option:

- (i) purchase Products from other sources without liability to Supplier, and require Supplier to reimburse **MLNA/MLMX** for any additional costs to **MLNA/MLMX** of obtaining the substitute Products compared to the Prices for such Products under this Agreement; or
- (ii) require Supplier to provide Products from other sources in quantities and at a time requested by **MLNA/MLMX** and at the Prices for Products hereunder.

(d) The rights granted to Supplier with respect to excused delays under this Section are intended to limit Supplier's rights under theories of force majeure, commercial impracticability, impracticability, or impossibility of performance, or failure of presupposed conditions or otherwise, including any rights arising under Section 2-615 or 2-616 of the South Carolina UCC.

17. Additional Obligations of Supplier.

(a) Supplier shall at all times comply with all Law applicable to this Agreement and its obligations under this Agreement, including Supplier's sale of Products. Without limiting the generality of the foregoing, Supplier shall:

- (i) at its own expense, maintain all certifications, credentials, licenses, and permits necessary to conduct its business relating to the sale of Products; ;
- (ii) not engage in any activity or transaction involving Products, by way of shipment, use, or otherwise, that violates any Law;
- (iii) comply with the Occupational Safety and Health, as amended, and all standards, rules, regulations, and orders issued pursuant thereto, and all other federal and state occupational safety and health statutes, the provisions of which are substantially the same as those found in the Occupational Safety and Health or administered by any state pursuant to that Act;
- (iv) furnish **MLNA/MLMX** with a Material Safety Data Sheet with each shipment or delivery of a hazardous chemical or material, in strict compliance with the hazard communication regulations of the Occupational Safety and Health Administration of the United States & Mexico Department of Labor and all state and local hazard communication, right-to-know and similar laws, rules and regulations.

	<p style="text-align: center;">MEKRA Lang North America, LLC 101 Tillessen Boulevard Ridgeway, SC 29130</p>	<p>LM 250 Rev # 17</p> <p>Page 15 of 19</p>
<p style="text-align: center;">Form</p>	<p style="text-align: center;">SUPPLIER AGREEMENT</p>	<p>Approved By: Bhuvesh Dhir Revised By: Manuel Martinez Released By: Renee Tuttle Release Date: 8/13/2024</p>

- (b) On request, Supplier shall furnish **MLNA/MLMX** any environmental certificates of compliance and/or permitting providing compliance with all applicable Laws. Supplier shall complete any environmental surveys or evaluations requested by **MLNA/MLMX**.
- (c) On request, Supplier shall furnish **MLNA/MLMX** certificates of compliance with all applicable Law. In addition, Supplier shall furnish certificates, data and any other documentation requested by **MLNA/MLMX**, verifying that Supplier is in complete compliance with the written specifications for Products. Such documentation shall include the results of any tests conducted on Products. Supplier shall, at time of delivery or invoicing, certify that Products sold hereunder were manufactured or produced in full compliance, to the date of certifications, as amended and all applicable United States and Mexican Law, including Department of Labor Regulations and the Fair Labor Standards Act.
- (d) Supplier guarantees compliance with non-discrimination in employment. Supplier shall file compliance reports with the appropriate federal agency and, on request, supply **MLNA/MLMX** with copies of the compliance reports and any other information necessary to demonstrate compliance. Supplier also guarantees compliance with employment of the handicapped, and applicable Law.
- (e) Supplier shall cause its Representatives to comply with the Foreign Corrupt Practices Act, including maintaining and complying with all policies and procedures to ensure compliance with this Act.
- (f) Supplier shall cause its Representatives to comply with the **MLNA/MLMX** Code of Conduct (Annex 4) including maintaining and complying with all policies and procedures to ensure compliance with this Code.
- (g) On **MLNA/MLMX's** request Supplier shall promptly provide all information necessary to export and import Goods under this Agreement, including, as applicable, the Export Control Classification Numbers (ECCN) and subheadings or munitions list category numbers, and shall Notify **MLNA/MLMX** of any changes to the information provided by Supplier to export and import Goods under this Agreement.
- (h) On **MLNA/MLMX's** request, Supplier shall provide to **MLNA/MLMX** all information (in sufficient detail), with written certifications thereof, to enable **MLNA/MLMX** to timely comply with all of **MLNA/MLMX's** and Customers' due diligence, disclosure and audit requirements under Section 1502 of the Dodd-Frank Wall Street Reform and Consumer Protection Act (the "Dodd-Frank Act") and Rule 13p-1 and Form SD under the Securities Exchange Act of 1934, and all similar, applicable statutes and regulations, including due inquiry of Supplier's supply chain (and certifications by such suppliers) identifying conflict minerals (as defined in Section 1502(e)(4) of the Dodd-Frank Act) contained in each Product and the country of origin of such conflict minerals (or, following due inquiry, why such country of origin cannot be determined).
- (i) Supplier shall, at Supplier's sole cost and expense, take such actions as are necessary or appropriate to ensure the uninterrupted supply of Products to **MLNA/MLMX** during any foreseeable or anticipated event or circumstance that could interrupt or delay Supplier's performance under this Agreement, including any labor disruption, whether or not resulting from the expiration of Supplier's labor contracts (and whether or not such occurrence constitutes a Force Majeure Event hereunder). Supplier shall Notify

	<p style="text-align: center;">MEKRA Lang North America, LLC 101 Tillessen Boulevard Ridgeway, SC 29130</p>	<p>LM 250 Rev # 17</p> <p>Page 16 of 19</p>
<p style="text-align: center;">Form</p>	<p style="text-align: center;">SUPPLIER AGREEMENT</p>	<p>Approved By: Bhuvesh Dhir Revised By: Manuel Martinez Released By: Renee Tuttle Release Date: 8/13/2024</p>

MLNA/MLMX at least 90 days before the termination or expiration of any collective bargaining or other labor agreement that relates to Supplier's delivery of Products. If an actual or potential labor dispute delays or threatens to delay Supplier's timely performance hereunder, Supplier shall immediately give notice thereof to **MLNA/MLMX**. Supplier, for a period of 30 days prior to the expiration of any of its labor agreements, shall maintain an additional inventory of 30 calendar days' supply of Products at a site separate from Supplier's unionized manufacturing facility or secure an alternative method of manufacture of Products at a facility not affected by the labor union in order to ensure the continued supply of Products to **MLNA/MLMX**.

- (j) Supplier shall promptly provide notice to **MLNA/MLMX** of any of the following events or occurrences, or any facts or circumstances reasonably likely to give rise to any of the following events or occurrences:
 - (i) any failure by Supplier to perform any of its obligations under this Agreement;
 - (ii) any delay in delivery of Products;
 - (iii) any defects or quality problems relating to Products;
 - (iv) any change in Control of Supplier;
 - (v) any deficiency in **MLNA/MLMX**'s specifications, samples, prototypes, or test results relating to this Agreement; or
 - (vi) any failure by Supplier, or its Representatives to comply with Law.

In addition, Supplier shall promptly Notify **MLNA/MLMX** of any change in Supplier's authorized Representatives, insurance coverage, or professional certifications.

18. Entire Agreement.

- (a) All of the terms and conditions to this Agreement are set forth herein, and include the terms and conditions contained in the referenced schedules & annexes. This Agreement supersedes all prior communications, representations or agreements between the Parties, whether verbal or written, regarding the subject matter hereof.
- (b) The invalidity, illegality or unenforceability of any one or more provisions of this Agreement shall in no way affect or impair the validity, legality or enforceability of the remaining provisions hereof, which shall remain in full force and effect.

19. Remedies and Waiver.

- (a) The remedies reserved to **MLNA/MLMX** or Supplier herein shall be cumulative and in addition to all other or further remedies provided by Law. No waiver by either Party of any breach, default or violation of any term, warranty, representation, agreement, covenant, condition or provision hereof shall constitute a waiver of any subsequent breach, default or violation of the same or other term, warranty, representation, agreement, covenant, condition or provision.
- (b) Should **MLNA/MLMX** employ an attorney or attorneys to enforce any of the provisions hereof or to protect its interests in any manner arising under this Agreement, or to recover damages for the breach hereof, and prevails in any action pursued in courts of competent jurisdiction (finality of which action is not legally contested) Supplier agrees to pay to **MLNA/MLMX** all reasonable costs, damages, and expenses, including attorney's fees, expended or incurred in connection therewith.

	<p style="text-align: center;">MEKRA Lang North America, LLC 101 Tillessen Boulevard Ridgeway, SC 29130</p>	<p>LM 250 Rev # 17 Page 17 of 19</p>
<p style="text-align: center;">Form</p>	<p style="text-align: center;">SUPPLIER AGREEMENT</p>	<p>Approved By: Bhuvesh Dhir Revised By: Manuel Martinez Released By: Renee Tuttle Release Date: 8/13/2024</p>

20. Notices.

All notices and other communications from either Party to the other hereunder shall be in writing and shall be deemed given when delivered personally, by courier service or when deposited in the U.S. Mail, certified or registered mail, return receipt requested, postage prepaid and properly addressed to the other Party at its address set forth below or such other address that the other Party may designate from time to time in accordance with this Section:

Supplier:

MEKRA Lang North America, LLC

Attn.: _____
101 Tillessen Boulevard
Ridgeway, SC 29130

21. Limit of Authority.

Both Parties are independent contractors, and this Agreement does not constitute either Party as the legal Representative of the other for any purpose whatsoever. Neither Party has authority to assume or create any obligation whatsoever, expressed, or implied, on behalf or in the name of the other Party, nor to bind the other in any manner whatsoever.

22. Modifications.

No modification, amendment, extension, renewal, rescission, termination or waiver of any of the provisions contained herein, or any future representation, promise or condition in connection with the subject matter hereof, shall be binding upon either party unless in writing and signed by an authorized Representative on its behalf.

23. Choice of Law and Forum.

- (a) This Agreement and all matters arising out of or relating to this Agreement, are governed by, and construed in accordance with, the Laws of the State of South Carolina, United States of America, without regard to the conflict of laws provisions thereof to the extent such principles or rules would require or permit the application of the Laws of any jurisdiction other than those of the State of South Carolina. The parties agree that the United Nations Convention on Contracts for the International Sale of Goods does not apply to this Agreement.
- (b) Each Party irrevocably and unconditionally agrees that it will not commence any action, litigation, or proceeding of any kind whatsoever against the other Party in any way arising from or relating to this Agreement in any forum other than the United States District Court for the District of South Carolina sitting in Columbia, South Carolina or, if such court does not have subject matter jurisdiction, the courts of the State of South Carolina sitting in Richland County, and any appellate court from any thereof. Each Party irrevocably and unconditionally submits to the exclusive jurisdiction of such courts and agrees to bring any such action, litigation, or proceeding only in the United States District Court for the District of South Carolina sitting in Columbia, South Carolina or, if such court does not have subject matter jurisdiction, the courts of the State of South Carolina sitting in Richland County. Each Party agrees that a final judgment in any such action, litigation, or proceeding is conclusive and may be enforced in other jurisdictions by suit on the judgment or in any other manner provided by Law.

	<p style="text-align: center;">MEKRA Lang North America, LLC 101 Tillessen Boulevard Ridgeway, SC 29130</p>	<p>LM 250 Rev # 17 Page 18 of 19</p>
<p style="text-align: center;">Form</p>	<p style="text-align: center;">SUPPLIER AGREEMENT</p>	<p>Approved By: Bhuvesh Dhir Revised By: Manuel Martinez Released By: Renee Tuttle Release Date: 8/13/2024</p>

24. Assignment or Delegation; Successors and Assigns.

Supplier may not assign any of its rights or delegate any of its obligations under this Agreement without **MLNA/MLMX's** prior written consent. Any purported assignment or delegation in violation of this Section is null and void. No assignment or delegation relieves the assigning or delegating Party of any of its obligations under this Agreement. This Agreement is binding on and inures to the benefit of the Parties to this Agreement and their respective permitted successors and permitted assigns.

25. General Provisions.

- (a) This Agreement shall be interpreted without regard to which Party initiated the drafting process or proposed or drafted particular language and shall not be construed for or against any Party.
- (b) This Agreement may be executed in one or more counterparts, each of which may be deemed an original instrument, but all of which together shall constitute but one instrument.
- (c) Subject to the limitations and other provisions of this Agreement: (a) the representations and warranties of the Parties contained herein shall survive the expiration or earlier termination of this Agreement; and (b) as well as any other provision that, in order to give proper effect to its intent, should survive such expiration or termination, shall survive the expiration or earlier termination of this Agreement.
- (d) Should this Agreement be translated from English into any other language, both versions of this Agreement are mutually binding. However, in the event there are conflicting interpretations and application of the Agreement between the versions, the English version shall control.
- (e) Neither Supplier nor any of its Representatives shall (orally or in writing) publicly disclose, issue any press release, or make any other public statement, or otherwise communicate with the media, concerning the existence of this Agreement or the subject matter hereof, without the prior written approval of **MLNA/MLMX.**

IN WITNESS WHEREOF, the Parties have executed this Agreement as of the day and year written above.

[INSERT SUPPLIER NAME]Supplier

**MEKRA Lang North America, LLC
MEKRA Lang Mexico S. de RL. de CV.**

Signature/Date

Signature/Date

Managing Director

Print name/Title

Print name

	<p style="text-align: center;">MEKRA Lang North America, LLC 101 Tillessen Boulevard Ridgeway, SC 29130</p>	<p>LM 250 Rev # 17</p> <p>Page 19 of 19</p>
<p style="text-align: center;">Form</p>	<p style="text-align: center;">SUPPLIER AGREEMENT</p>	<p>Approved By: Bhuvesh Dhir Revised By: Manuel Martinez Released By: Renee Tuttle Release Date: 8/13/2024</p>

Schedule A

This Supplier Agreement – **Schedule A** is hereby made part of Supplier Agreement for Purchase and Sale of Products by and between **Supplier’s Name** and **MLNA/MLMX**. The Agreement was signed on **Date** and these terms will become valid as of the date of signature.

In consideration of the mutual covenants contained herein, and other good valuable consideration the receipt and sufficiency of which is hereby acknowledged, **MLNA/MLMX** and Supplier’s Name agree to the following:

1. The Base Piece Prices for Products referenced in the Agreement shall be as following:

Example

Part Number	Rev.	Description	EAU	Cost
4067XXXXXXXX	A	Main Mirror Glass	65,990	\$1.03

***Volumes listed are not guaranteed but to be used for forecast purposes only**

- 2. Supplier Lead Times:**
- 3. Production Part Payment Terms: 90 days**
- 4. Tooling and Rack Payment Terms: TBD**
- 5. Supplier Capacity Confirmation: TBD**
- 6. Delivery Term: TBD**
- 7. Yearly Rebate: Credit Note of 5% based on Annual Purchase Volume**
- 8. Production Releases: Volumes listed on Schedule A, are not guaranteed but are to be used for forecast purposes only.** Supplier shall schedule releases based on “Six Month Product Estimate” provided by **MLNA/MLMX**. Releases can be modified periodically based on changes in requirements and do not necessarily have to correspond precisely to weekly required amounts in light of production flexibility limitations. Supplier is 100% responsible to track any change in the releases demand via EDI and notify immediately to **MLNA/MLMX** in case Supplier its not able to fulfill the demand as requested, in case of any comment from Supplier will be considered as an acceptance.
- 9. Safety Stock:** Supplier must maintain a safety stock of raw material to cover a minimum order for 4 weeks demand to cover drop in orders.

	<p style="text-align: center;">MEKRA Lang North America, LLC 101 Tillessen Boulevard Ridgeway, SC 29130</p>	<p>SD 8.4-4 Rev # 1</p> <p>Page 1 of 10</p>
<p>Support Document</p>	<p style="text-align: center;">MEKRA Lang North America Quality Requirements for Production Material</p>	<p>Approved By: Manuel Gomez Created By: Manuel Gomez Released By: Renee Tuttle Release Date: 01/14/2022</p>

This Quality Agreement is made and entered into on Date, by and between **MEKRA Lang North America, LLC** (“MLNA”/ “MLMX” or “Buyer”) located in address, **MEKRA Lang México S. de R.L. de C.V.** located in address, and **Supplier’s Name** (the “Seller” or “Supplier”) located in address. Collectively referred to as the “Parties” and each is a “Party.”

1. Quality and Environmental Management System

Supplier shall be IATF 16949 certified and shall implement a corresponding quality management system. Supplier shall provide proof of its certification to the MLNA/MLMX. If the Supplier is not IATF 16949 certified, Supplier shall submit a plan to achieve the IATF 16949 certification to the MLNA/MLMX, ISO 9001 certification shall be mandatory for the Supplier.

Supplier with ISO 9001 certification shall implement a corresponding quality management system. Supplier shall provide proof of its certification to the MLNA/MLMX.

Supplier shall strive to implement or maintain and continuously improve the environmental requirements of the then-current version of the ISO 14001. Any deviation from or non-compliance with the above referenced requirements shall be communicated to the MLNA/MLMX with remedial actions and time schedule. In addition, Supplier is obligated to comply with all applicable national and local environmental laws and regulations, as well as any customer environmental requirements communicated to Supplier.

Supplier shall provide proof of its certification to MLNA/MLMX (Quality Team)

In addition, specific quality requirements are also set forth in additional agreements between the Parties or are contained in technical specifications and documentation, drawings, internal forms, third-party forms, samples, etc. made available to the Supplier by MLNA/MLMX.

1.2 Subcontractor Quality and Environmental Management Subcontractor

Supplier shall provide its subcontractors which supply them with Products, Product Parts or related goods and services with all applicable MLNA/MLMX and/or Customer specific quality requirements and is responsible for their implementation.

Supplier is also responsible for all quality issues with the goods and services of any subcontractors and sub-suppliers.

Supplier shall also be responsible to verify the implementation of the above-mentioned requirements and ensure that the subcontractor has a certified quality management system according to the most current version of the ISO 9001 and ISO 14001.

1.3 Quality Targets

The Supplier shall continuously strive to fulfill the zero-defect philosophy within the framework of these Quality Requirements for Production Material.

	<p style="text-align: center;">MEKRA Lang North America, LLC 101 Tillessen Boulevard Ridgeway, SC 29130</p>	<p>SD 8.4-4 Rev # 1</p> <p>Page 2 of 10</p>
<p>Support Document</p>	<p style="text-align: center;">MEKRA Lang North America Quality Requirements for Production Material</p>	<p>Approved By: Manuel Gomez Created By: Manuel Gomez Released By: Renee Tuttle Release Date: 01/14/2022</p>

1.4 Audit

The Supplier shall allow the MLNA/MLMX to audit its quality assurance measures to verify all quality requirements of MLNA/MLMX. Supplier agrees that MLNA/MLMX may perform an audit at any time, with appropriate notice. Supplier must ensure that MLNA/MLMX may audit such quality measures at its subcontractors.

The Supplier acknowledges and ensures that the MLNA/MLMX may conduct such audits together with its customer. Supplier shall grant MLNA/MLMX, and its Customer, access to all manufacturing facilities, test sites, warehouses, adjacent areas, as well as all quality relevant documents. MLNA/MLMX will inform the Supplier of the audit results. If the MLNA/MLMX 's audit finds that corrective actions are necessary, the Supplier is to create an action plan detailing all corrective actions which must be implemented in a timely manner.

1.5 Quality Planning

Part of the quality management system of the Supplier is a proactive quality planning that takes into account the standards of the VDA and AIAG.

Supplier shall utilize the processes/methods detailed below:

- Feasibility study
- Construction FMEA (if responsibility lies with the supplier)
- Process FMEA
- Resource planning
- Measuring and monitoring devices
- Statistical process control (SPC)
- Capability indices (cmk, cpk)
- Planning of logistic processes
- Manufacturing- and testing instructions
- Provisions for subcontractors (if necessary)
- Process flow diagram
- Control plan
- Emergency concept
- Traceability

1.5.1 Creating a Process Flow Diagram

Supplier shall clearly describe and document its processes, material, Products and Product Parts flows (including production equipment and inspection points from receiving through to shipment). In addition, Supplier shall ensure throughout the entire process flow that materials and Product Parts are stored separately in batches and that they are processed in accordance with the "first in, first out" principle. Process flow diagrams are the basis for the creation of a Failure Mode and Effects Analyses ("FMEA") and production control plans and must be created by Supplier. On request of the MLNA/MLMX, the process flow has also to be shown on the factory layout.

1.5.2 Risk Analysis (FMEA)

Supplier shall conduct a design FMEA for the Products and Product Parts for which it has design responsibility. Supplier shall conduct a process FMEA. to assess all influencing factors before Tools and/or equipment are

	<p style="text-align: center;">MEKRA Lang North America, LLC 101 Tillessen Boulevard Ridgeway, SC 29130</p>	<p>SD 8.4-4 Rev # 1</p> <p>Page 3 of 10</p>
<p>Support Document</p>	<p style="text-align: center;">MEKRA Lang North America Quality Requirements for Production Material</p>	<p>Approved By: Manuel Gomez Created By: Manuel Gomez Released By: Renee Tuttle Release Date: 01/14/2022</p>

manufactured, as well as in the event of complaints. In addition, continuous updates to the process, Products and Product Parts shall be evaluated and potentially implemented by Supplier in the FMEA. Supplier shall allow MLNA/MLMX to view the FMEA as necessary for the purposes of the Purchase Contract.

1.5.3 Machine and Process Capability

The Supplier shall evaluate the machine and process capability in line with the current version of the VDA volume 4 and the QS-9000 (including the production part approval process ("PPAP") and the current version of the statistical process control ("SPC"). In addition, possible additional requirements applicable in connection with the Supplier Agreement shall always be taken into consideration.

The following limit values shall apply (for e.g. BM S, BM Z, BM F, [SC, CC]):

- Machine capability value „cmk“ > 1.67
- Preliminary process capability „cpk“/„ppk“ > 1.67
- Long-term process capability „cpk“/„ppk“ > 1.33

The following shall apply for safety and legally relevant characteristics:

- Preliminary process capability „cpk“/„ppk“ > 2.00
- Long-term process capability „cpk“/„ppk“ > 1.67

If higher (stricter) project-specific values are required, the Supplier shall comply with these.

The terms cpk / ppk are used analogously to the process behavior according to the QS-9000 for stable / unstable processes.

All functional and safety-relevant characteristics shall be analyzed and documented in detail to verify their suitability of the manufacturing process.

If a capability value is not achieved, the Supplier must validate its Products with suitable test methods.

In series production, Supplier shall continuously provide documented evidence that required capability values for special safety related, legal and regulatory as well as functional and requirement relevant characteristics have been met (significant/critical characteristics /according VDA: BM S, BM Z or BM F). Supplier shall choose a suitable process, e.g. statistical process control or manual control card technique. If a capability value is not achieved, Supplier shall optimize the production process so that the required value is achieved to assure defect-free delivery of Products.

1.6 Changes

When planning the start of modification measures, the Supplier shall inform MLNA/MLMX in writing, of any changes to Products, the manufacturing process including process transfer, and the quality management system, at least three (3) months before the planned implementation. The same period of time also applies to Supplier's subcontractors. A change request for the carrying out of a change shall be submitted to MLNA/MLMX in a timely manner. Supplier shall duly document any approved changes in accordance with reasonable requirements communicated to Supplier by MLNA/MLMX (if any).

Only after receipt of the written approval of the MLNA/MLMX, the Supplier is entitled to carry out the proposed changes to Products, the manufacturing process including process transfer, and the quality management system.

	<p style="text-align: center;">MEKRA Lang North America, LLC 101 Tillessen Boulevard Ridgeway, SC 29130</p>	<p>SD 8.4-4 Rev # 1</p> <p>Page 4 of 10</p>
<p>Support Document</p>	<p style="text-align: center;">MEKRA Lang North America Quality Requirements for Production Material</p>	<p>Approved By: Manuel Gomez Created By: Manuel Gomez Released By: Renee Tuttle Release Date: 01/14/2022</p>

In the case of an approved change to Products, Supplier shall only deliver unchanged Products up to a date to be agreed. MLNA/MLMX 's approval of any changes shall not release Supplier from its sole responsibility to deliver Products as agreed. MLNA/MLMX is entitled to request reasonable changes to Products in terms of design and the performance. With respect to such Buyer requested changes, the parties shall reasonably agree on the consequences for the Purchase Contract, including additional costs, cost reductions and changes to delivery dates, periods and sequences.

1.7 Documentation

1.7.1 General

Supplier shall organize the documentation of its quality management system including the quality assurance measures in an orderly manner and make the documentation available to MLNA/MLMX at any time upon request. The Supplier must implement all documentation requirements for quality management systems detailed in the most current version of VDA 1 and the IATF 16949, unless otherwise agreed.

All necessary documents relating to release, operation, maintenance, and repair as well as the documentation relating to the manufacture of Samples (dimensional and material test reports, functional tests) shall be sent to MLNA/MLMX at no charge and without having been specifically requested by MLNA/MLMX. Test records from a production or a batch shall be included with the relevant series delivery of product in accordance with the Supplier Agreement and must be sent in parallel to MLNA/MLMX Quality Department. For documents that require special archiving, a test certificate shall be submitted to MLNA/MLMX upon request.

Supplier shall allow MLNA/MLMX access to all samples, test results and relevant documents.

1.7.2 Archiving Duration

Documents requiring special archiving shall be archived for fifteen (15) years. All quality-relevant documents, especially those relating to measured values and test results, shall be archived for five (5) years after creation.

2. Quality Requirements

2.1 General Requirements

Supplier shall coordinate all quality requirements for Products with the quality requirements in the entire Customer Vehicle project. Supplier shall prepare quality schedules which shall describe in detail the quality requirements, development cycles and quality measures according to the stage of development. Possible conflicts with quality requirements and possible risks shall be reported in writing and without undue delay to MLNA/MLMX 's quality planning department.

2.2 Quality Planning

Supplier shall be solely responsible for:

- The identification of all possible Product, process and scheduling risks in accordance with the Product Specification and the commissioning scope.

The definition and identification of special characteristics and their handling in line with the then-current version of VDA volume 1 respectively further applicable customer specific requirements.

2.3 Customer Specific Requirements

2.3.1 Maturity Increase

	<p style="text-align: center;">MEKRA Lang North America, LLC 101 Tillessen Boulevard Ridgeway, SC 29130</p>	<p>SD 8.4-4 Rev # 1</p> <p>Page 5 of 10</p>
<p>Support Document</p>	<p style="text-align: center;">MEKRA Lang North America Quality Requirements for Production Material</p>	<p>Approved By: Manuel Gomez Created By: Manuel Gomez Released By: Renee Tuttle Release Date: 01/14/2022</p>

As part of a continuous increase in maturity level, MLNA/MLMX ordered Products are to be further developed and optimized during the pre-series. Defects or deviations from the original specifications are to be reported by means deficiencies shall be promptly corrected by the Supplier. Any necessary changes to the specifications require the express written approval of the MLNA/MLMX.

2.3.2 Product Part History

The Product Part history documentation shall also be made electronically available to the MLNA/MLMX 's quality department in advance.

2.3.3 Original Samples and Customer Specifications

The Supplier must implement all applicable norms and customer specific requirements for the Product. Supplier shall contact MLNA/MLMX in the event that it needs the original Samples or Product/project specific Customer specifications to fulfill its obligations under the Supplier Agreement.

2.4 Non-conforming material requirements

The supplier shall take full responsibility for the quality of delivered products and services. All non-conforming material concerns shall be given priority in resolving issues, including visits to customer site to address any concerns. If deemed necessary by MLNA, the supplier must be prepared to make the following provisions:

- Use All Available Resources to Determine the Cause of Failure
- Define and Implement Effective Corrective or Preventive Action
- Halt Production and/or Delivery or potential delivery of identified product
- Support the product or service through sorting, customer visits, and end user visits related to issue

As part of the non-conforming material process, MLNA/MLMX may perform an evaluation of supplied products or services in order to support internal production scheduling, including sorting, rework or replacement at customer's site. All related costs shall be forwarded to the supplier in accordance with the problem notification and charge back process. MLNA/MLMX will take precautions as possible to limit associated costs. If the situation does not require immediate sorting and evaluation by MLNA/MLMX to support internal production scheduling, suppliers will be given the option to provide sorting resources or indicate MLNA/MLMX to sort, at which time an estimate of rework costs will be determined. Supplier's failure to respond within Seven (7) business days with an RMA# and a decision regarding disposition of rejected material constitutes agreement by the supplier with MLNA/MLMX to scrap the rejected material on MLNA/MLMX's site and process the debit as reported. If the supplier needs the material back at their facilities the supplier is responsible for the logistics operations or accepting charges related with the logistic operation from MLNA/MLMX's

2.5 Scorecards

The supplier will receive every month a scorecard from MLNA/MLMX. On the Scorecard , MLNA/MLMX is evaluating the following points (Delivery performance, Quality PPM, RMA, Technical Support, PNR 8D response & Quality System).

	<p style="text-align: center;">MEKRA Lang North America, LLC 101 Tillessen Boulevard Ridgeway, SC 29130</p>	<p>SD 8.4-4 Rev # 1</p> <p>Page 6 of 10</p>
<p>Support Document</p>	<p style="text-align: center;">MEKRA Lang North America Quality Requirements for Production Material</p>	<p>Approved By: Manuel Gomez Created By: Manuel Gomez Released By: Renee Tuttle Release Date: 01/14/2022</p>

Supplier will receive the Supplier Score/Rank by MLNA/MLMX. If needed, the Supplier needs to share action plan to get inside target within the first 3 days after notice of scorecards by MLNA/MLMX. Supplier needs to follow up the action plan and achieve target score within the following month.

Supplier Score/Rank	
90-100	No se requieren acciones / No Action Required
70-89	Discutir la Calificación con el Proveedor y obtener un plan de acción y compromiso para mejora / Discuss Rating with Supplier and obtain action plan and commitment for improvement
60-69	No hay nuevos negocios incrementales; evaluar y movimiento potencial a un proveedor alternativo / No new incremental business; evaluate, and potential move to alternate supplier
<59	No hay nuevos negocios incrementales; pasar a un nuevo proveedor / No new incremental business; move to new supplier

Supplier is responsible of chargeback costs generated by Quality / Delivery issues. These chargebacks include:

- Line down costs.
- Expedited material costs.
- Admin fees
- Containment activities at MLNA/MLMX and at our customers facilities.
- Reworks /Sorting activities due to Quality issues.
- PNR generate a cost , that need to be paid by the supplier.

2.7 Special Processes (AIAG Special Processes)

Suppliers with internal or outsourced “special processes,” as identified by the Automotive Industry Action Group (AIAG), are required to conform with relevant AIAG Special Process documents: CQI-9 Heat Treat Systems Assessment, CQI-11 Plating Systems Assessment, CQI-12 Coating Systems Assessment, CQI-15 Welding Systems Assessment, CQI-17 Soldering Systems Assessment, CQI-23, Molding System Assessment, CQI-27 Casting System Assessment, and CQI-29 Brazing System Assessment. In addition, CQI-28 Traceability Guidelines or other standards and/or guidelines specified on product drawings/specifications or other contractual provisions must be met. Ongoing assessments shall be conducted, at a minimum, annually, to ensure continuous compliance. The supplier shall keep records as evidence of compliance, as well as all appropriate action plans to address any “not satisfactory”, “needs immediate action” or “failed” findings. The results of the assessments and action plans shall be provided to MLNA/MLMX.

2.8 Paint Certification

If the supplier provides parts painted to MLNA/MLMX, Supplier needs to update the paint certificate every 12 months.

2.8.1 Aluminum Certification

If the supplier provides aluminum parts to MLNA/MLMX, Supplier needs to update the aluminum certificate every 12 months.

2.9 PPAP Documentation

Supplier will provide PPAP documentation according with customer drawings at a level 3, unless MLNA/MLMX require a different level of PPAP documentation. Supplier will cover all expenses of PPAP documentation.

	<p style="text-align: center;">MEKRA Lang North America, LLC 101 Tillessen Boulevard Ridgeway, SC 29130</p>	<p>SD 8.4-4 Rev # 1</p> <p>Page 7 of 10</p>
<p>Support Document</p>	<p style="text-align: center;">MEKRA Lang North America Quality Requirements for Production Material</p>	<p>Approved By: Manuel Gomez Created By: Manuel Gomez Released By: Renee Tuttle Release Date: 01/14/2022</p>

3. Sampling

3.1 General

The assessment of the production processes and the initial sample inspection are the basis for the series release of the delivered products. The prerequisite for the processing of the initial sampling is the completeness of the sampling documents (incl. accepted IMDS entry).

3.2 Preliminary Samples

Unless otherwise agreed, for each level of samples the Supplier shall submit at minimum 5 dimensionally measured samples (using gauge, if applicable) free of charge including Product Part history and Product rating sheet to the MLNA/MLMX 's quality representative.

3.3 Initial Samples

"Initial Samples" for production process and Product release ("PPF") and PPAP are Products and Product Parts which have been manufactured entirely under series production conditions and tested regarding all required and agreed features. Unless otherwise agreed, for testing and approval of a new Product, samples must be provided at its own cost by the Supplier.

The Supplier is required to implement and complete the PPF/PPAP process as required and on schedule prior to the first series delivery. Supplier shall finalize a time schedule with MLNA/MLMX.

All documents relating to Initial Samples and the PPF/PPAP report including all cover sheets of all subcontractors and (sub-) suppliers of MLNA/MLMX shall be share with Quality Department.

The process release is an integral part of the foregoing procedure and shall be verifiably performed by Supplier. MLNA/MLMX can accompany the release or carry it out instead of Supplier.

The delivery documents including materials, Products and Product Parts history shall be visibly enclosed. According to the respective agreement, fulfillment of the specifications can be documented with certificate of conformity or material data sheets. These shall contain a plan-actual evaluation.

The submission level of the PPF/PPAP shall be agreed between the parties. VDA volume 2, submission level 2, or PPAP level 3 guidelines, in their then-current version shall generally apply, unless agreed on otherwise in writing. The number of Product Parts to be sampled under VDA 2 is five (5) parts and under PPAP is six (6) parts per material number / cavity. Possible triggers for the PPF / PPAP process shall be considered analogous VDA Volume 2 and PPAP.

The Supplier shall create and archive all documents and samples respecting the highest possible submission level / stage. MLNA/MLMX may request further documentation concerning the agreed submission level at the later stage.

Within the framework of the PPF/PPAP, the delivered Products, Product Parts, materials and material groups shall be entered into the International Material Data System (IMDS) of MLNA/MLMX by Supplier.

	<p style="text-align: center;">MEKRA Lang North America, LLC 101 Tillessen Boulevard Ridgeway, SC 29130</p>	<p>SD 8.4-4 Rev # 1 Page 8 of 10</p>
<p>Support Document</p>	<p style="text-align: center;">MEKRA Lang North America Quality Requirements for Production Material</p>	<p>Approved By: Manuel Gomez Created By: Manuel Gomez Released By: Renee Tuttle Release Date: 01/14/2022</p>

The corresponding material data sheet identification number shall be specified in the PPF/PPAP coversheet report. With the first series process parts Supplier shall start with the PPF / PPAP. The PPF / PPAP of Supplier's purchased parts shall be provided to MLNA/MLMX upon request. In the event of any nonconformance, a complete Product deviation approval may be requested by Supplier, provided that MLNA/MLMX is under no obligation to grant such approval.

If non-conformances are determined in the Initial Samples, Supplier shall be required to carry out a root cause analysis and to communicate suitable measures for manufacturing defect-free Products to MLNA/MLMX. Incomplete, rejected or only conditionally approved Initial Samples shall receive negative consideration in MLNA/MLMX 's supplier rating. Additional costs which are caused by Supplier in this regard, as well as costs incurred by MLNA/MLMX due to failure to meet scheduling including agreed delivery dates, periods and sequences, shall be carried, and reimbursed to MLNA/MLMX, by Supplier.

3.4 Archiving of Initial Sample

The Initial Samples shall be archived by Supplier and made available as required to Mekra by MLNA/MLMX.

4. Production under Series Conditions

4.1 Manufacturability Evaluation

The Supplier must perform a feasibility analysis prior to the quote submission. For this purpose, the Supplier obtains independently the necessary standards and guidelines (in particular DIN, EN, ISO, VDA and customer requirements) on which is referenced in the request. Supplier shall verify all technical requirements and documents in regards to capable production, while considering its own production facilities and capacities. In case ambiguities arise regarding the technical requirements and documents, Supplier shall immediately clarify these issues with MLNA/MLMX 's quality department.

4.2 Decrease in Quality

Supplier shall immediately notify MLNA/MLMX in writing of any detected or anticipated manufacturing or quality problems, as well as any knowledge or suspicion that defective Products or parts thereof ("Product Parts") have already been delivered to MLNA/MLMX.

In case of manufacturing or quality problems, in particular a decrease in quality, or a complaint from MLNA/MLMX, Supplier shall immediately communicate adequate corrective measures to MLNA/MLMX. Until the implementation of such corrective measures, MLNA/MLMX may take, or demand that Supplier takes, special measures (e.g. higher frequency of testing) to ensure the quality of the delivered Products. Any additional costs of MLNA/MLMX resulting from such measures shall be reimbursed by Supplier, insofar as the manufacturing or quality problems originate from the sphere of responsibility of Supplier and there is no documented evidence that they were caused by MLNA/MLMX or Customer OEM. The MLNA/MLMX shall inform the Supplier about all associated costs in a timely manner.

	<p style="text-align: center;">MEKRA Lang North America, LLC 101 Tillessen Boulevard Ridgeway, SC 29130</p>	<p>SD 8.4-4 Rev # 1</p> <p>Page 9 of 10</p>
<p>Support Document</p>	<p style="text-align: center;">MEKRA Lang North America Quality Requirements for Production Material</p>	<p>Approved By: Manuel Gomez Created By: Manuel Gomez Released By: Renee Tuttle Release Date: 01/14/2022</p>

4.4 Requalification

The Supplier must conduct an annual requalification for all supplied Products, in accordance with the requirements of IATF 16949 at its own expense and confirm the requalification in MLNA/MLMX 's Supplier Guidelines. Project-specific requirements of the Customer shall be considered.

The Supplier must conduct the first requalification within twelve (12) month after the initial sample approval and / or after the SOP (Start of Production) of each individual project, whichever occurs first. All subsequent requalification must be conducted within twelve (12) months after the last requalification.

Upon MLNA/MLMX's request, Supplier shall provide MLNA/MLMX with thorough documentation and evidence of successful completion of all requalification tests.

The Supplier must clearly plan and document the scope of the requalification of Products and processes in its control plan.

5. Testing Equipment / Production Equipment

Supplier shall ensure that all necessary testing equipment is suitable for the particular measurement purpose, is available at all times, and is permanently monitored, calibrated and kept in good condition

If testing equipment / production equipment is made available to Supplier by MLNA/MLMX or Customer OEM, MLNA/MLMX instructions shall be followed, and the testing equipment shall be integrated into Supplier's quality management system. In addition, all applicable Customer OEM requirements, as communicated to Supplier, shall be fulfilled.

6. Complaint Management

6.1 Types of Complaints

MLNA/MLMX shall file complaints to the Supplier for defective Products. In particular the following types of complaints can be filed:

- incoming goods complaints
- complaints stemming from the MLNA/MLMX 's production process
- complaints for 0-km-failures (refer to errors that occur during the delivery, installation or the final inspection of the Products by the Customer)
- field complaints (refer to defects that are discovered after delivery of the customer vehicle to the Final Customer)
- complaints regarding serial damages
- miscellaneous complaints (for example regarding transportation)

6.2 General Complaint Management Process

If such complaint is determined by MLNA/MLMX and communicated to Supplier, Supplier shall immediately initiate corrective actions which ensure the permanent removal of the defect and its root cause.

Supplier shall bear, and reimburse MLNA/MLMX for, all costs and expenses incurred by MLNA/MLMX due to complaints.

Supplier shall, within twenty-four (24) hours, submit a written statement of the root cause of the defect and immediately take actions according to steps one through three of the 8D report.

	<p style="text-align: center;">MEKRA Lang North America, LLC 101 Tillessen Boulevard Ridgeway, SC 29130</p>	<p>SD 8.4-4 Rev # 1</p> <p>Page 10 of 10</p>
<p>Support Document</p>	<p style="text-align: center;">MEKRA Lang North America Quality Requirements for Production Material</p>	<p>Approved By: Manuel Gomez Created By: Manuel Gomez Released By: Renee Tuttle Release Date: 01/14/2022</p>

Afterwards, other points relevant in connection with the complaint such as root cause analyses and corrective actions shall be implemented and documented within two (2) weeks for middle-term actions, and four (4) weeks for long-term actions.

For the purpose of closing the PNR, the effectiveness of the corrective actions shall be verified and documented by MLNA/MLMX Staff. At MLNA/MLMX 's request, a photograph of the reference Sample with a completed label shall be attached to the test report.

6.3 Special Measures for Repetitive Defects, Controlled Shipping Level (CSL)

The Supplier shall comply with the Controlled Shipping Level (CSL) rules listed below:

"Controlled Shipping" is a demand by the MLNA/MLMX that a Supplier put in place a redundant inspection process to sort for a specific nonconformance, while implementing a root-cause problem solving process.

The redundant inspection is in addition to normal controls.

The MLNA/MLMX 's representative is authorized to perform onsite effectiveness checks (e.g. audits).

Exit criteria for both Controlled Shipping Levels shall be set.

Two levels of Controlled Shipping exist:

a) Controlled Shipping - Level 1:

The Supplier shall enact an inspection process, conducted by its own employees and at its own expense, in order to isolate MLNA/MLMX from receipt of nonconforming Products/material.

b) Controlled Shipping - Level 2:

This includes the same processes as Controlled Shipping - Level 1, but the additional inspection process is performed by a third party representing MLNA/MLMX 's interests specific to the containment activity. The third party is selected by the Supplier, approved by the MLNA/MLMX, and paid for by the Supplier.

7. Definitions

Capitalized terms used herein and defined in the Supplier Agreement and shall have the meaning as defined in the Supplier Agreement.

	<p style="text-align: center;">MEKRA Lang North America, LLC 101 Tillessen Boulevard Ridgeway, SC 29130</p>	<p>SD 8.4-3 Rev # 1</p> <p>Page 1 of 5</p>
<p>Support Document</p>	<p style="text-align: center;">Mekra Lang North America Logistics Requirements for Production Material</p>	<p>Approved By: Manuel Gomez Created By: Manuel Gomez Released By: Renee Tuttle Release Date: 01/14/2022</p>

List of abbreviations/definitions:

- AIAG Automotive Industry Action Group
- EDI Electronic data interchange
- IPPC International Plant Protection Convention
- JIS Just-In-Sequence
- JIT Just-In-Time
- OEM Original Equipment Manufacturer (Vehicle manufacturer)
- VAT ID Value added tax identification number
- VDA German Association of the Automotive Industry
- VMI Vendor (Supplier) Managed Inventory
- e.g. for example

Scope as standard and information

These documents are valid worldwide in their then-applicable version, binding for Supplier and serve to inform Supplier of MLNA/MLMX’s logistics requirements.

1. Logistic requirements of Supplier

Any situation that could put specified delivery times, dates, periods, or sequences at risk has to be reported to the Supply Chain Management/Logistics department of MLNA/MLMX without undue delay.

Capacities must be planned in the way that the planned quantities of Products can be produced with maximum five working days and in three shifts each day per week.

All communication with MLNA/MLMX must be carried out in English or Spanish, stating the MLNA/MLMX’s material number.

1.1 Organization of logistics

Supplier shall immediately notify MLNA/MLMX of:

- Name fixed Supply Chain Management/Logistics contacts and their representatives who are authorized to make decisions and available at all times during business hours.
- Name a competent point of contact and ensure his availability for special operations outside of business hours.

1.2 Notification of changes of logistic variables

Supplier shall immediately notify MLNA/MLMX of:

- Each change in the location of the production or dispatching plant.
- IT system changes which are relevant to logistics.
- Changes to its operational logistics structure; such changes shall be immediately notified to MLNA/MLMX 's logistics department.
- Changes to Products which influence the packaging or procurement process. Such changes must be approved in writing by the responsible MLNA/MLMX’s contact prior to the introduction of the change.

	<p style="text-align: center;">MEKRA Lang North America, LLC 101 Tillessen Boulevard Ridgeway, SC 29130</p>	<p>SD 8.4-3 Rev # 1</p> <p>Page 2 of 5</p>
<p>Support Document</p>	<p style="text-align: center;">Mekra Lang North America Logistics Requirements for Production Material</p>	<p>Approved By: Manuel Gomez Created By: Manuel Gomez Released By: Renee Tuttle Release Date: 01/14/2022</p>

2. Ordering process and Release Schedule

The entire ordering process shall be carried out preferentially by EDI as far as possible, if EDI is not available, the ordering process shall be conducted via email/Excel file.

The Release Schedule alone shall define the delivery quantity and time. No Supplier order confirmation shall be sent for orders on MLNA/MLMX 's Release Schedule.

2.1 Forms of delivery

The following forms of delivery shall be used by MLNA/MLMX:

The weekly forecast Release Schedule is standard.

If the special forms daily call-off, JIS or VMI are used in addition to the weekly forecast Release Schedule, a process specific individual agreement shall be concluded. These forms apply for Supplier delivering more than one time per week and require Supplier to follow MLNA/MLMX's business hours and holiday planning.

The delivery date indicated shall always refer to the date of arrival at MLNA/MLMX's receiving plant. The date of shipping and notification shall be planned with respect to the delivery date and the process times (according to negotiated Incoterms e.g. in case of supplier FOB supplier location or nearest port Delivery date should be considered as shipping date). Determination and compliance shall be ensured by Supplier. Process times according to MLNA/MLMX 's transport requirements shall apply for carriage forward shipments; for carriage paid shipments, responsibility for the duration of transport shall lie with Supplier.

If the delivery date indicated is a public holiday in the country/federal state of MLNA/MLMX 's delivery address, the delivery date shall be the last working day before the public holiday.

2.2 Receiving plant

Shipments must be labeled with the receiving plant and, if necessary, with the unloading point specified in the Release Schedule. The receiving plant is not necessarily also the production site. Under certain circumstances, Products may, in MLNA/MLMX 's sole discretion, only be collected at the receiving plant and then be transported to the production sites.

Products may also be delivered directly to individual plants after special agreement

2.3 Delivery addresses / invoice addresses

The delivery and invoice addresses must be taken out of the Supplier Agreement, Schedule "A" portion. Agreed between supplier and MLNA/MLMX.

2.4 Special shipments

If Supplier's actions (e.g. late deliveries or delivery of defective Products) present a risk of shutting down assembly lines of MLNA/MLMX or MLNA/MLMX's Customer, special shipments from third party companies to avert such shutdowns generate claims for damages of MLNA/MLMX against Supplier. Such special deliveries may be commissioned by MLNA/MLMX's responsible logistics department to third party companies and are generally notified to Supplier in writing.

Supplier shall, in accordance with IATF 16949, be required to document all additional freight costs for special deliveries. Supplier must also document the causes for all special deliveries and supply this documentation to MLNA/MLMX at MLNA/MLMX's request at any time.

	<p style="text-align: center;">MEKRA Lang North America, LLC 101 Tillessen Boulevard Ridgeway, SC 29130</p>	<p>SD 8.4-3 Rev # 1</p> <p>Page 3 of 5</p>
<p>Support Document</p>	<p style="text-align: center;">Mekra Lang North America Logistics Requirements for Production Material</p>	<p>Approved By: Manuel Gomez Created By: Manuel Gomez Released By: Renee Tuttle Release Date: 01/14/2022</p>

3. Logistics costs

Detailed container and transport costs are to be included in the Supplier's Binding Offer as requested by the MLNA/MLMX in his Request for Quote (RFQ) and broken down according to the specification below.

4. General

- a) The container shall prevent damage. Aspects to be taken into account are the type of Product, the method of transport, quality requirements and legal regulations.
- b) The delivered Products must be free from any contamination.
- c) Unnecessary complex containers shall be avoided wherever possible. Filling material shall be reduced to a minimum. The choice of container should be process-oriented and shall meet the requirements of an economical and environment-friendly use of resources.
- d) The container should be without identifiable defects which may affect transport and protection functions. The relevant standards/regulations are to be respected.
- e) Containers must not extend beyond the sides of the palettes.
- f) Weights of individual packages must observe health and safety requirements. In any case, deviations must be indicated on the packaging data sheet.
- g) Access to the container contents must not be possible without leaving visible marks.
- h) It must be possible to completely empty and easily clean reusable containers.
- i) Supplier shall mark containers clearly and visibly with the information required for their proper handling. The fixing of markings (label/tag) shall be ensured with spots of glue-labels or the existing plug-in opening. If necessary, additional symbols for the handling and characteristics of the container shall be attached. A fully labeled surface should be avoided. The empty reusable special container shall only be marked with MLNA/MLMX's identification label.
- j) Reusable special containers shall be marked with MLNA/MLMX's identification label as agreed. The preparation of these labels shall be carried out through the relevant MLNA/MLMX planner.
- k) Empty container requests to meet MLNA/MLMX's demand shall be discharged by Supplier in a timely manner. Five working days shall be calculated from the receipt of the request until the shipping of the container. Deviations may be agreed on in a separate agreement in writing.
- l) Unless otherwise stated in the Supplier Agreement Contract, responsibilities and costs for the return of empty containers shall be as follows:
 - If MLNA/MLMX pays for the delivery of the filled container, return of the empty container is paid by MLNA/MLMX.
 - If Supplier pays for the delivery of the filled container, return of the empty container shall be paid by Supplier. The return of empty containers shall be carried out either as a direct swap or through separate supply/collection.

6. Supply conditions/ trade terms/ INCOTERMS 2021 terms

A single INCOTERM 2021 term shall always be agreed for the total scope of supply of Supplier.

6.1 ASN (advance shipping notice) requirements

Supplier must be capable of transmitting an ASN for all series deliveries within 15 minutes after the truck, or, as applicable, other means of transport, has left the origin. The ASN must be transmitted digitally to MLNA/MLMX

	<p style="text-align: center;">MEKRA Lang North America, LLC 101 Tillessen Boulevard Ridgeway, SC 29130</p>	<p>SD 8.4-3 Rev # 1</p> <p>Page 4 of 5</p>
<p>Support Document</p>	<p style="text-align: center;">Mekra Lang North America Logistics Requirements for Production Material</p>	<p>Approved By: Manuel Gomez Created By: Manuel Gomez Released By: Renee Tuttle Release Date: 01/14/2022</p>

prior to the receipt of the delivery. Specifications of ASN formatting will be communicated to Supplier via MLNA/MLMX's logistics department.
If Supplier is not able to transmit ASNs, MLNA/MLMX reserves the right to request Supplier to provide ASN via a third party.

6.2 Accompanying documents

Each shipment to MLNA/MLMX requires 2 forms of documentation: bill of lading and packing slip; all suppliers that bill to MNLA and ship to MLMX need to include commercial invoice on each shipment.

The bill of lading should include the following but be not limited to:

Description of Products, quantity of Products and load units shipped, weight of shipment, NMFC (National Motor Freight Classification) class

The packing slip should include the following but not be limited to:

Date of shipment, point of origin (name and address), Supplier number (assigned by MLNA/MLMX), point of delivery (name and address), delivery note number (sequential, non-repeating), net weight of shipment, gross weight of shipment, MLNA/MLMX's Product number, Supplier Product number (if applicable with Revision Level), Country of origin (per Product number), description of Product, pack count per container, number of containers shipped, quantity of Products shipped (per Product number), lot / batch number (if applicable), special notation if hazardous material is included in shipment.

International shipments must also be accompanied by:

- Invoice(s)
- Copy (copies) of the origin certificate(s)

The formatting of Supplier packing slip has to be approved by MLNA/MLMX 's logistics department prior to the first shipment made using said documentation.

6.3 Clearance times at Supplier for carriage forward shipments

The Supplier shall meet the following clearance times (unloading/ loading):

For Europe and Asia:

- for Products up to 2.5 load meters maximum 30 minutes.
- for Products above 2.5 load meters maximum 45 minutes.
- for complete loading maximum 120 minutes.

7. Emergency strategies

To safeguard the delivery process, Supplier shall develop general emergency strategies for the following issues and provide them immediately if requested:

- Exchange of information/data processing
- Shipment Processing
- Packaging
- Transport
- Missing Parts
- Distribution by Sub-Suppliers

	<p style="text-align: center;">MEKRA Lang North America, LLC 101 Tillessen Boulevard Ridgeway, SC 29130</p>	<p>SD 8.4-3 Rev # 1</p> <p>Page 5 of 5</p>
<p>Support Document</p>	<p style="text-align: center;">Mekra Lang North America Logistics Requirements for Production Material</p>	<p>Approved By: Manuel Gomez Created By: Manuel Gomez Released By: Renee Tuttle Release Date: 01/14/2022</p>

- Other Potential Risks (Supplier Specific)

8. Right to charge costs and additional expenses

In cases of damage caused culpably by Supplier for the following logistical violations, costs, internal MLNA/MLMX additional expenses and additional transport costs are to be paid by Supplier to MLNA/MLMX, including but not limited to:

- Permanent/repeated backlog
- Deviations from agreed packaging
- Faulty Supplier Packaging
- Missing reusable packaging (e.g. if not requested promptly)
- Missing or faulty accompanying documents and/ or EDI
- Faulty Pre-Packaging
- Multiple Deliveries outside agreed delivery frequency
- Violation of transport requirements
- Costs resulting from customs handling
- Violation of loading times over-delivery / advance delivery
- False inventory record keeping of reusable containers not accepted by Buyer
- Missing returns of reusable containers owned by Buyer



Supplier
Packaging & Labeling
Requirements

	<p>MEKRA Lang North America, LLC 101 Tillessen Boulevard Ridgeway, SC 29130</p>	<p>SD 7.4-51 Rev 7 Page 2 of 42</p>
<p>Support Document</p>	<p>SUPPLIER PACKAGING AND LABELING REQUIREMENTS</p>	<p>Approved By: Bhuvesh Dhir Revised By: Mauricio Alvarez Released By: Renee Tuttle Release Date: 2/22/2024</p>

Contents



.....	1
1.0 Introduction	5
2.0 Compliance	5
3.0 Environmental Considerations	5
4.0 Packaging Responsibilities	6
4.1 General	6
4.2 Essential Packaging Functions	6
4.3 Compliance with Regulatory Requirements	6
4.4 Compliance with Import/Export Packaging Requirements	6
5.0 General Packaging Requirements	7
5.1 Packaging Costs	7
5.2 Packaging Material	7
5.3 Ergonomics	7
5.4 Unique Packaging Requirements	7
6.0 Shipping Instructions and Documentation	7
6.1 Destination Label	7
6.2 Packing List	8
6.3 Numbering Cartons and Containers	9
6.4 Handling Instructions	9
7.0 Shipping Container Specifications	9
7.1 Definition	9

	<p style="text-align: center;">MEKRA Lang North America, LLC 101 Tillessen Boulevard Ridgeway, SC 29130</p>	<p>SD 7.4-51 Rev 7 Page 3 of 42</p>
<p style="text-align: center;">Support Document</p>	<p style="text-align: center;">SUPPLIER PACKAGING AND LABELING REQUIREMENTS</p>	<p>Approved By: Bhuvesh Dhir Revised By: Mauricio Alvarez Released By: Renee Tuttle Release Date: 2/22/2024</p>

7.2	Hand-Handled Container Requirements	9
7.3	Mechanically-Handled Container Requirements	10
7.4	Container Height.....	10
7.5	Temperature	10
7.6	Moisture.....	10
7.7	Special Considerations	10
7.8	Salvaged Packaging Materials.....	11
8.0	Corrugated Fiberboard Specifications.....	11
8.1	General.....	11
8.2	Certificate of Box Manufacturer.....	11
9.0	Dunnage Material.....	11
10.0	Pallet Specifications	12
10.1	General.....	12
10.2	Pallet Size Requirements.....	12
10.3	Construction Requirements.....	12
11.0	Load Containment	13
11.1	General.....	13
11.2	Metallic Strapping	13
11.3	Plastic Strapping.....	13
11.4	Plastic Stretch Film	13
11.5	Shrink Film.....	13
11.6	Unitizing Adhesives	14
11.7	Stacking Cartons	14
11.8	Loading of Cartons	14
11.9	Mixed Load Procedure.....	14
12.0	Package Testing	14
13.0	MLNA/MLMX-Owned Returnable Containers.....	15
14.0	Supplier-Owned Returnable Containers	15
15.0	Mode of Transportation	15
16.0	Hazardous Materials.....	15
17.0	Bar Coded Shipping Label Requirements	16
17.1	General.....	16
17.2	Quality	16
17.3	Label Size and Materials.....	16
17.4	Label Information	17
17.5	Bar Code Symbology	19

	<p style="text-align: center;">MEKRA Lang North America, LLC 101 Tillessen Boulevard Ridgeway, SC 29130</p>	<p>SD 7.4-51 Rev 7 Page 4 of 42</p>
<p style="text-align: center;">Support Document</p>	<p style="text-align: center;">SUPPLIER PACKAGING AND LABELING REQUIREMENTS</p>	<p>Approved By: Bhuvesh Dhir Revised By: Mauricio Alvarez Released By: Renee Tuttle Release Date: 2/22/2024</p>

17.6	Label Location and Protection.....	19
17.7	Special Labels	20
18.0	Individual Piece Part Bar-Coding Requirements.....	21
18.1	General.....	21
18.2	Quality	21
18.3	Label, Size, Material, and Special Requirements	21
18.4	Label Information	22
18.5	Bar Code Symbology	22
18.6	Approval of Bar Code Label by MLNA/MLMX	23
19.0	New Product and Part Changes	23
19.1	Trial Parts	23
19.2	PPAP Samples	23
19.3	Safe Launch	23
20.0	Exhibits.....	25

	MEKRA Lang North America, LLC 101 Tillessen Boulevard Ridgeway, SC 29130	SD 7.4-51 Rev 7 Page 5 of 42
Support Document	SUPPLIER PACKAGING AND LABELING REQUIREMENTS	Approved By: Bhuvesh Dhir Revised By: Mauricio Alvarez Released By: Renee Tuttle Release Date: 2/22/2024

1.0 Introduction

This manual has been prepared to assist Suppliers in meeting **Mekra Lang North America/Mekra Lang Mexico (MLNA/MLMX)** packaging, labeling and shipping requirements.

Suppliers are responsible for packaging and labeling parts so that they arrive, at **MLNA/MLMX** and/or the point-of-use, in damage free condition, with appropriate documentation. In addition, packaging must be economical with minimum impact on the environment and labeling must be in accordance with industry standards. It is essential that Suppliers and **MLNA/MLMX** cooperate to achieve acceptable packaging and labeling at reasonable cost, in our mutual interest and to our customer's satisfaction. Questions regarding compliance, content, intent or recommendations for these requirements should be directed to your **MLNA/MLMX**'s buyer or to Mekra Lang North America, LLC 101 Tillessen Blvd Ridgeway, S.C. 29130. Telephone (803) 337-5264.

2.0 Compliance

Supplier compliance to the requirements in this document is mandatory. However, some parts supplied to **MLNA** may require special packaging or labeling not covered in this document. If you supply this type of part, contact your **MLNA/MLMX**'s buyer for assistance in development of a package or label compatible with **MLNA/MLMX**'s requirements. Any deviation from the requirements listed in this document must have approval by **MLNA/MLMX**.

3.0 Environmental Considerations

MLNA/MLMX is participating in industry efforts toward the reuse and recycling of packaging materials. Successful implementation of waste minimization programs, recycling, and use of returnable containers has substantially eliminated or reduced the amount of materials sent for disposal. In addition, we are investigating new technologies, materials and distribution alternatives which will minimize the overall impact of packaging waste on the environment. The concept of Product Stewardship, in which industry assumes the responsibility of their products and packaging from conception to disposal, is vital in achieving an environmentally responsible packaging strategy.

	MEKRA Lang North America, LLC 101 Tillessen Boulevard Ridgeway, SC 29130	SD 7.4-51 Rev 7 Page 6 of 42
Support Document	SUPPLIER PACKAGING AND LABELING REQUIREMENTS	Approved By: Bhuvesh Dhir Revised By: Mauricio Alvarez Released By: Renee Tuttle Release Date: 2/22/2024

MLNA/MLMX requests that Suppliers commit to Product Stewardship and faithfully practice the 3 R’s principle of Reduce, Re-use and Recycle. By doing so, the elimination and reduction of packaging related wastes will reduce packaging costs as well as minimize the impact of packaging on the environment.

4.0 Packaging Responsibilities

4.1 General

Suppliers are responsible for designing packaging that will deliver parts and material to MLNA/MLMX and/or the point-of-use in damage free condition, assuming normal handling and storage.

4.2 Essential Packaging Functions

Packaging must perform a number of essential functions during transportation and storage. Suppliers should consider the following functions in designing a package for their product:

- Protection of the product from physical damage,
- Convenience of use, safety and ease of handling,
- Compliance to legal and regulatory requirements,
- Communication of information (labeling), and
- Environmental acceptability and ease of disposal or recycling.

4.3 Compliance with Regulatory Requirements

As a supplier for MLNA/MLMX you are required to develop packaging and use packaging materials which are consistent with regulations established by state, provincial, or local governments wherever your package is discarded (recycled, reused, disposed of, etc.). MLNA/MLMX will attempt to notify suppliers of any relevant legislation, which may apply directly to containers, and packaging shipped to MLNA/MLMX locations. However, the supplier has ultimate responsibility for assuring their packaging is in compliance with regulations.

4.4 Compliance with Import/Export Packaging Requirements

Special considerations **must** be made when importing product to MLNA/MLMX. Please refer to the United States Department of Agriculture – Animal & Plant Health Inspection Service (APHIS) website.

Web link: <http://www.aphis.usda.gov/ppq/wpm/index.html>

	MEKRA Lang North America, LLC 101 Tillessen Boulevard Ridgeway, SC 29130	SD 7.4-51 Rev 7 Page 7 of 42
Support Document	SUPPLIER PACKAGING AND LABELING REQUIREMENTS	Approved By: Bhuvesh Dhir Revised By: Mauricio Alvarez Released By: Renee Tuttle Release Date: 2/22/2024

5.0 General Packaging Requirements

5.1 Packaging Costs

All part quotations are to include packaging and labeling costs. The supplier is responsible for packaging and labeling as required by this document and must include the costs for all materials and labor in the piece-part price at the time of quotation.

5.2 Packaging Material

Packaging should consist of recycled materials where possible and be cost effective. Plastic material must be labeled in accordance with the Society of the Plastics Industry Recycling Symbolology (See Exhibit A and Section 6.8). Corrugated containers must display a Certificate of Box Manufacturer in a readily visible location on the container (See Exhibit B and Section 7.2). The use of salvaged containers, pallets and other packaging material must have written approval from **MLNA/MLMX**. No extra labels shall be visible on the packaging. All old labels or markings on the package must be removed or covered.

5.3 Ergonomics

All containers and packaging must be designed with consideration given to ease of handling and part removal. Appropriate consideration must be given to height restrictions, weight restrictions, carton disassembly and any other issues that may affect worker safety.

5.4 Unique Packaging Requirements

Unique packaging requirements such as rust prevention, weight, fragility and surface appearance, which are not covered by these guidelines, are the responsibility of the parts supplier.

6.0 Shipping Instructions and Documentation

6.1 Destination Label

1. All destination labels shall be machine-printed. Handwritten or illegible labels are unacceptable.
2. Destination labels shall be located on two adjacent sides of the container or package, where possible.
3. Suppliers shall refer to the **MLNA/MLMX**'s Purchase Order or Supplier Release Authorization for the correct shipping address.

	MEKRA Lang North America, LLC 101 Tillessen Boulevard Ridgeway, SC 29130	SD 7.4-51 Rev 7 Page 8 of 42
Support Document	SUPPLIER PACKAGING AND LABELING REQUIREMENTS	Approved By: Bhuvesh Dhir Revised By: Mauricio Alvarez Released By: Renee Tuttle Release Date: 2/22/2024

6.2 Packing List

1. All shipments shall contain at least one packing list.
2. Packing lists shall bear the proper **MLNA/MLMX**'s vendor code.
3. Packing lists shall contain a Shipper Number (SID).

Packing lists should have a separate location for the **Shipper Number** (SID).

The **Shipper Number** (SID) shall be a unique number assigned by the supplier (not necessarily in sequential order) that specifically identifies a shipment. This number shall be referenced on invoices presented to **MLNA/MLMX** for payment. In this way, each shipment will have a unique "control" number that differentiates it from others (for accounting purposes).

Only one **Shipper Number** (SID) shall be used per shipment, and **Shipper Number** (SID) shall not be repeated within any calendar year. The **Shipper Number** (SID) shall be a maximum of ten (10) alphanumeric characters. For suppliers using Electronic Data Interchange (EDI), this SID shall be the same SID used on advanced shipping notices (type 856) and invoice (type 810) transactions. Suppliers may use any convenient number (B/L, Work Order, Invoice #, Sales Order, etc.) for the **Shipper Number** if it conforms to the above guidelines and is **clearly** identified as the **Shipper Number** on the packing list.

4. All parts and material included in a shipment shall be represented on the packing list by the following:

The **MLNA/MLMX**'s Part Number,
 The **MLNA/MLMX**'s Purchase Order Number/Scheduling Agreement
 The quantity shipped (by the Supplier).

5. Location of Packing List

The packing list shall be enclosed in the carton or container, on top of the parts, or shall be securely attached to the outside in a protective envelope labeled "Packing List". For shipment of multiple cartons or containers, the location of the packing list shall be labeled or marked in some way stating "Packing List" or "Packing List Inside" on two adjacent sides of the carton or container carrying the packing list. For

	MEKRA Lang North America, LLC 101 Tillessen Boulevard Ridgeway, SC 29130	SD 7.4-51 Rev 7 Page 9 of 42
Support Document	SUPPLIER PACKAGING AND LABELING REQUIREMENTS	Approved By: Bhuvesh Dhir Revised By: Mauricio Alvarez Released By: Renee Tuttle Release Date: 2/22/2024

international shipments, attach one packing list to the outside marked “Customs Packing List” and, in addition, enclose one packing list inside the carton or container.

6.3 Numbering Cartons and Containers

For shipment of multiple cartons or containers, each individual carton or container must be consecutively numbered and marked on the outside (e.g., 1 of 3, 2 of 3, 3 of 3). This will assist in identifying individual cartons that may get separated during shipment.

6.4 Handling Instructions

Material handling instructions should be marked in bold letters and proportionately sized to the container or carton.

- **Direction of Travel** – If a package is designed to travel in a specific direction, it should be indicated on two adjacent sides of the package.
- **Stacking Instructions** – If a package will not support the weight of other packages, it should be indicated in two visible locations. The use of a cone is advisable to prevent the stacking of boxes or pallets.
- **Fragile** – If a product is fragile such that it may be damaged with normal handling or if it requires special handling, it should be indicated in two visible locations on the package.

7.0 Shipping Container Specifications

7.1 Definition

Expendable containers are containers that are designed for one-way use. Exhibit C illustrates typical expendable shipping containers.

7.2 Hand-Handled Container Requirements

1. Gross Weights shall not exceed 30 lbs.
2. Corrugated cartons are the most common hand-handled containers, and are acceptable with the following qualifications:
3. The container must be expendable (designed for one-way use).

	<p>MEKRA Lang North America, LLC 101 Tillessen Boulevard Ridgeway, SC 29130</p>	<p>SD 7.4-51 Rev 7 Page 10 of 42</p>
<p>Support Document</p>	<p>SUPPLIER PACKAGING AND LABELING REQUIREMENTS</p>	<p>Approved By: Bhuvesh Dhir Revised By: Mauricio Alvarez Released By: Renee Tuttle Release Date: 2/22/2024</p>

4. Use a regular slotted carton (RSC) except when other styles may be dictated by part characteristics.
5. The unsupported bottom of a carton must be able to hold the contents.
6. Hand-holds are desirable for bulky packages.
7. Construction must be in accordance with the Corrugated Fiberboard Specifications in Section 7 and Fiberboard Box Specifications in Exhibit D of this document.

7.3 Mechanically-Handled Container Requirements

1. Gross Weight shall not exceed 3,500 lbs.
2. All shipments of mechanically handled containers must be on expendable wooden pallets as specified in Section 9 of this document.

7.4 Container Height

Containers should not exceed 42” in height (including the pallet) where part size allows. Any exceptions must be approved in advance by **MLNA/MLMX**.

7.5 Temperature

Expendable containers should be designed to withstand temperature variations from -40° C to 80° C.

7.6 Moisture

Expendable containers should be designed to withstand 90% humidity at 150°F (65.6°C) exposure during transit and storage.

7.7 Special Considerations

The use of non-recyclable wax impregnated and/or polyethylene (PE) coated corrugated fiberboard is prohibited.

The use of lead and cadmium is prohibited.

The use of asphaltic tape is prohibited.

The use of expanded polystyrene (EPS) is prohibited. All plastic material must be labeled in accordance with the Society of the Plastics Industry (SPI) guidelines (See Exhibit A). For more information, contact SPI at 1275 K Street N.W., Suite 400, Washington, D.C. 20005.

	<p>MEKRA Lang North America, LLC 101 Tillessen Boulevard Ridgeway, SC 29130</p>	<p>SD 7.4-51 Rev 7 Page 11 of 42</p>
<p>Support Document</p>	<p>SUPPLIER PACKAGING AND LABELING REQUIREMENTS</p>	<p>Approved By: Bhuvesh Dhir Revised By: Mauricio Alvarez Released By: Renee Tuttle Release Date: 2/22/2024</p>

7.8 Salvaged Packaging Materials

Reuse programs may be established in controlled circumstances where packages are designed for multiple uses and/or distribution environments. The use of salvaged materials and reuse of cartons, pallets, crates, and other materials must be authorized by **MLNA/MLMX**.

8.0 Corrugated Fiberboard Specifications

8.1 General

Corrugated fiberboard is the primary material to be used for one-way expendable shipping containers.

MLNA/MLMX has historically required suppliers to use corrugated cartons with a minimum burst strength specification. However, Alternative Rule 41 of the Uniform Freight Classification and Item 222 of the National Motor Freight Classification allows packaging engineers to use edge-crush test (ECT) as an alternative to burst strength (Reference Exhibit D). The resulting packages have improved stacking strength with less corrugated material as compared to containers designed using burst strength specifications. Suppliers are encouraged to investigate the use of such alternatives when designing corrugated cartons in order to:

Provide for improved stacking strength of corrugated containers,

Increase the recycled content of corrugated paper,

Reduce the overall amount of fiber used per shipping container.

8.2 Certificate of Box Manufacturer

MLNA/MLMX requires all corrugated containers be stamped with the Certificate of Box Manufacturer (Reference Exhibit B), as indicated in Item 222-1 of the National Motor Freight Classification.

9.0 Dunnage Material

MLNA/MLMX encourages the use of paper-based rather than plastic-based dunnage material. Paper-based material is easily recycled along with corrugated containers, and does not require intermediate steps for segregation of materials. The use of foam or Styrofoam dunnage material must have written approval from **MLNA/MLMX** prior to use.

	MEKRA Lang North America, LLC 101 Tillessen Boulevard Ridgeway, SC 29130	SD 7.4-51 Rev 7 Page 12 of 42
Support Document	SUPPLIER PACKAGING AND LABELING REQUIREMENTS	Approved By: Bhuvesh Dhir Revised By: Mauricio Alvarez Released By: Renee Tuttle Release Date: 2/22/2024

10.0 Pallet Specifications

MLNA/MLMX will not accept pallets with any damage or defects. Pallets should be new or in near new condition and must remain intact and properly functioning throughout their intended lifespan. Suppliers are responsible for failure of their pallets while in transit to MLNA/MLMX. All pallets must be “Heat Treated”, constructed, and marked in accordance with Pallet Specifications paragraphs 10.2 and 10.3 below. Supplier shipments that do not comply with this requirement will be subject to an MLNA/MLMX repackaging charge, advised to the supplier in the form of an MLNA/MLMX Debit Memo.

10.1 General

The proper use and design of **Heat Treated** wood pallets is critical to assure part protection and overall container performance, and to make the most efficient use of storage and trailer space.

10.2 Pallet Size Requirements

Unless authorized or requested by MLNA/MLMX and, where part size permits, the **Heat Treated standard pallet size for a repetitive part is 48” by 40” by 4” with 4-way entry. Pallets must be stamped HT on 2 sides and must have 4 –way roll in entry with 2 equal fork openings measuring a minimum of 2.5” x 9” on the stringer side and a minimum of 3.5” x 28” on the stringer side. Pallets with a center stringer dimension wider than 2” are not permitted.** If a pallet dimension is greater than standard 48” by 40” then the use must be pre-approved by MLNA/MLMX.

10.3 Construction Requirements

All pallets must provide 4-way fork entry and be of double-face, non-reversible wood construction (Reference Exhibit F). Pallets constructed of other-than-wood material must be approved by MLNA/MLMX.

A minimum 28” fork opening width must be maintained.

A minimum 3-1/2” fork opening height must be maintained.

Construction Specifications:

1. Top and bottom deck board width: minimum 3.5”
2. Top and bottom deck board thickness: minimum ½”
3. Stringer dimensions: standard 2” by 4” (Stringer type pallets)

	<p>MEKRA Lang North America, LLC 101 Tillessen Boulevard Ridgeway, SC 29130</p>	<p>SD 7.4-51 Rev 7 Page 13 of 42</p>
<p>Support Document</p>	<p>SUPPLIER PACKAGING AND LABELING REQUIREMENTS</p>	<p>Approved By: Bhuvesh Dhir Revised By: Mauricio Alvarez Released By: Renee Tuttle Release Date: 2/22/2024</p>

11.0 Load Containment

11.1 General

The decision to use strapping, stretch film, shrink film, or unitizing adhesives for load containment must fully evaluate both performance and environmental considerations. Suppliers must select the load containment option, which provides damage protection and optimum load containment with minimal environmental impact.

11.2 Metallic Strapping

The use of metallic strapping is discouraged, but is recognized as the most appropriate material for certain applications.

11.3 Plastic Strapping

1. All plastic strapping must be of either Polypropylene (translucent clear only) or Polyester (translucent green only) materials. The color requirement aids in material identification for recycling purposes.
2. All plastic strapping must be free of metal clips and shall utilize either heat seal or friction weld as a sealing method.

11.4 Plastic Stretch Film

Plastic stretch film has a number of performance advantages, particularly for small cartons and parts shipped loose on pallets. Suppliers should investigate recyclability and adequacy for the application prior to use. In many cases, stretch film is used when the application calls for strapping.

1. All stretch film must be of linear low-density polyethylene (LLDPE) resin.
The use of polyvinyl chloride (PVC) film is prohibited.
2. All stretch film must be clear.
Tinted or colored film is prohibited.

11.5 Shrink Film

Shrink film offers some unique advantages for specific packaging applications and is considered an acceptable material if used within physical limitations. Suppliers should investigate recyclability and adequacy for the application prior to the use of shrink film.

	<p>MEKRA Lang North America, LLC 101 Tillessen Boulevard Ridgeway, SC 29130</p>	<p>SD 7.4-51 Rev 7 Page 14 of 42</p>
<p>Support Document</p>	<p>SUPPLIER PACKAGING AND LABELING REQUIREMENTS</p>	<p>Approved By: Bhuvesh Dhir Revised By: Mauricio Alvarez Released By: Renee Tuttle Release Date: 2/22/2024</p>

11.6 Unitizing Adhesives

Unitizing adhesive is a clear, water-soluble liquid, which is applied to the top and sides of corrugated cartons by spraying or brushing. The liquid forms a fiber bond, which prevents cartons from shifting, slipping or sliding off the pallet. **MLNA/MLMX** encourages suppliers to use unitized adhesives if recyclability of the cartons is not compromised.

11.7 Stacking Cartons

Suppliers should consider all the conditions under which their cartons and containers must perform.

Compression strength should be a primary consideration. Two-thirds of the stacking strength of a corrugated fiberboard carton is concentrated at the corners. Failure to properly utilize the corner strength of the carton(s) frequently leads to carton failure. Corrugated cartons will lose strength if stacked improperly or under adverse conditions (See Exhibit H).

11.8 Loading of Cartons

To minimize manual handling and to allow for stacking, all cartons must be “palletized” in individual layers on the pallet (See Exhibit I). The “pyramiding” of cartons is strictly prohibited (See Exhibit I). The supplier is responsible to assure that packaging is consistent with this policy. If material release quantities do not permit shipment of individual layers of cartons, **MLNA/MLMX** will assist in establishing consistent release quantities and/or alternative methods of packaging.

11.9 Mixed Load Procedure

When stacking cartons on a pallet and the shipment consists of more than one part number, organize the pallet by like part number. It is acceptable to mix different part numbers on a pallet only after full pallets of like part numbers have been built. Exhibit J illustrates when it is acceptable to ship different part numbers on the same pallet.

12.0 Package Testing

To assure satisfactory package performance throughout the distribution cycle, the testing of all packages prior to use is encouraged.

The American Society for Testing and Materials (ASTM) has issued standardized test methods which govern testing of packaging systems. Suppliers to **MLNA/MLMX** are encouraged to use the ASTM

	MEKRA Lang North America, LLC 101 Tillessen Boulevard Ridgeway, SC 29130	SD 7.4-51 Rev 7 Page 15 of 42
Support Document	SUPPLIER PACKAGING AND LABELING REQUIREMENTS	Approved By: Bhuvesh Dhir Revised By: Mauricio Alvarez Released By: Renee Tuttle Release Date: 2/22/2024

standards for testing packages. The standards can be obtained from the ASTM at 1916 Race Street, Philadelphia, PA 19103.

13.0 MLNA/MLMX-Owned Returnable Containers

The use of MLNA/MLMX-owned returnable containers must be negotiated as part of the agreement to supply parts to MLNA/MLMX. The MLNA/MLMX’s Purchasing Department will maintain an “Authorized MLNA/MLMX-Owned Returnable Container Listing” for suppliers who are approved to use MLNA/MLMX-owned returnable containers. The supplier is responsible for maintenance of the returnable in a clean and functional manner. The supplier is responsible to remove **all of the old labels** prior to reuse for every shipment.

14.0 Supplier-Owned Returnable Containers

The use of Supplier-owned returnable containers must be negotiated as part of the agreement to supply parts to MLNA/MLMX. The supplier is responsible for maintenance of the returnable container in a clean and functional manner. The supplier is responsible to remove **all of the old labels** prior to reuse for every shipment.

15.0 Mode of Transportation

MLNA/MLMX’s Supply Chain Management Department will designate the most economical mode of transportation and carrier routes to be used. The determination depends, to a large extent, upon the volume, weight and quantity of parts to be shipped. All packaging must be designed to absorb shock and vibration forces incurred in all types of transportation environments. However, no specific recommendations will be made in this document due to the variety of packaging and shipping modes.

16.0 Hazardous Materials

The U.S. Department of Transportation has established packaging regulations for materials determined to be hazardous as defined in two volumes of Title 49, Code of Federal Regulations parts 100 through 177, and parts 178 through 199. Included in this category are explosives, compressed gases, flammables, oxidizing materials, poisons, irritating materials, etiologic agents, blasting agents, radioactive materials, corrosives, and hazardous wastes.

	MEKRA Lang North America, LLC 101 Tillessen Boulevard Ridgeway, SC 29130	SD 7.4-51 Rev 7 Page 16 of 42
Support Document	SUPPLIER PACKAGING AND LABELING REQUIREMENTS	Approved By: Bhuvesh Dhir Revised By: Mauricio Alvarez Released By: Renee Tuttle Release Date: 2/22/2024

The first volume contains regulations on classification, packaging, marking, labeling, loading, paperwork, and other issues. The second volume sets forth shipping container specifications for many types of materials.

All suppliers shipping these type materials to **MLNA/MLMX** are required to adhere to these regulations.

Copies of the regulations can be obtained from:

Superintendent of Documents

U.S Government Printing Office

Washington, D.C. 20402.

17.0 Bar Coded Shipping Label Requirements

17.1 General

These specifications, which apply to bar codes for shipping labels, were developed according with the AIAG Shipping / Parts Identification Label Standard (AIAG: B-10, 2004).

For more information on AIAG Standards, contact the Automotive Industry Action Group, 26200 Lahser Road, Southfield, MI 48034.

17.2 Quality

The use of bar code systems is intended to increase productivity, reduce costs and improve data accuracy within the automobile and truck manufacturing industries. An important aspect of any bar code system is that of quality. When labels cannot be decoded fast and accurately, the advantages of bar coding are lost.

Suppliers have the responsibility to provide bar code labels that meet the specification of this document and those of the Print Quality Guideline in Section 4 of AIAG B-1. It is recommended that verification audits be used in conjunction with statistical process control techniques to assure shipping label quality.

17.3 Label Size and Materials

Label dimensions should be in accordance with the dimensions shown in Exhibit K. All other exhibits are for illustrative purposes only, and may not be to scale or bar code quality standards.

The recommended label size is 4.0” high by 6.5” wide, which should cover all conditions. The minimum label size shall be 4.0” high by 5.0” wide. The label paper shall be white with black printing. Adhesive

	<p>MEKRA Lang North America, LLC 101 Tillessen Boulevard Ridgeway, SC 29130</p>	<p>SD 7.4-51 Rev 7 Page 17 of 42</p>
<p>Support Document</p>	<p>SUPPLIER PACKAGING AND LABELING REQUIREMENTS</p>	<p>Approved By: Bhuvesh Dhir Revised By: Mauricio Alvarez Released By: Renee Tuttle Release Date: 2/22/2024</p>

labels can be pressure sensitive or dry gummed as long as adherence to the package substrate is assured, application is wrinkle-free, and for use on expendable packaging only.

Use the methods shown in Exhibit L to affix the label to the package or container, or use another method with **MLNA/MLMX**'s approval.

17.4 Label Information

1. Data Areas and Titles

The part number, quantity, supplier number, serial number, purchase order and line number data shall be displayed in both human readable characters and bar code symbols (Reference Exhibits M and N). Each data area shall be separated by border lines and shall contain the title and data identifier in the upper left hand corner. Titles and data identifiers shall be printed in 0.1” high letters. The Supplier’s name, city, state and zip code shall appear at the bottom of the label, and shall be in printed in 0.1” high letters. Human readable data characters shall be a minimum of 0.1” high. Bar code symbols shall be directly below the human readable data characters and shall be a minimum of 0.5” high.

2. Data Identifier Characters

A data identifier character shall be used to identify specific data.

The data identifier shall be printed separately in human readable characters under the title.

The data identifier shall not be included in the human readable characters.

The data identifier shall be included in the bar code symbol.

The data identifier characters are as follows:

- P – Part Number**
- R – Part Revision Level**
- Q – Quantity Shipped**
- V – Supplier Number**
- S – Unique Serial Number (SID)**
- M – Unique Serial Number (SID) - Master Label**
- G – Unique Serial Number (SID) - Mixed Load**

	<p>MEKRA Lang North America, LLC 101 Tillessen Boulevard Ridgeway, SC 29130</p>	<p>SD 7.4-51 Rev 7 Page 18 of 42</p>
<p>Support Document</p>	<p>SUPPLIER PACKAGING AND LABELING REQUIREMENTS</p>	<p>Approved By: Bhuvesh Dhir Revised By: Mauricio Alvarez Released By: Renee Tuttle Release Date: 2/22/2024</p>

- K – Purchase Order Number**
- ML – Manufactures Lot Number**
- L – Delivery Location of the parts**
- MD – Manufactures Date**
- CO – Country Origin**
- SN – Supplier Name**

See Exhibit N

3. Part Number

Part numbers shall be the same part numbers designated on the **MLNA/MLMX**'s Purchase Order/Scheduling Agreement or Material Release Authorization. The maximum length of the part number shall be twenty (20) alphanumeric characters. The length of the bar code symbol shall not exceed 5.5”.

4. Quantity

The maximum length for the quantity is six (6) numeric characters. When the unit of measure is pieces, no notation is required. When the unit of measure is not pieces (i.e., pounds, pairs, feet, etc.), it shall be printed in human readable form only. When used, the unit of measure abbreviation (Reference Exhibit O) shall be directly to the right of the human readable quantity.

The unit of measure shall not be bar coded.

5. Supplier Number

The supplier number will be the Vendor Code assigned by **MLNA/MLMX** to each Supplier location.

The maximum length for the supplier number is five (5) characters.

6. Serial Number (Shipment Identification Number)

The serial number shall be the Shipper number (SID) described in Section 5.2.3 of this document.

The maximum length for this number shall be nine (9) alphanumeric characters.

	<p>MEKRA Lang North America, LLC 101 Tillessen Boulevard Ridgeway, SC 29130</p>	<p>SD 7.4-51 Rev 7 Page 19 of 42</p>
<p>Support Document</p>	<p>SUPPLIER PACKAGING AND LABELING REQUIREMENTS</p>	<p>Approved By: Bhuvesh Dhir Revised By: Mauricio Alvarez Released By: Renee Tuttle Release Date: 2/22/2024</p>

The line number item refers to the line number on the Purchase Order. The maximum length of the line number shall be three (3) characters.

7. Manufacture Lot Number

The manufacture lot number not to exceed one coil/molt/batch or one 24 hour day, whichever is the lesser of the two. The lot number may be the manufacture date as well. For containers that a coil/molt/batch/date change over are required to meet a standard full pack, the second number is to be included. There shall not be more than two manufactures lot numbers per label.

8. Manufacture Date

The manufacture date not to exceed 24 hours. For containers that a coil/molt/batch/date change over are required to meet a standard full pack, the second number is to be included. There shall not be more than two manufactures dates per label.

17.5 Bar Code Symbology

Bar codes shall be the 3-of-9 (Code 39) type as specified by the Automotive Industry Action Group (AIAG: B-1, 1984).

1. Code Configurations

The four (4) characters (\$,/,+,%) of the 3-of-9 symbology shall not be used in the bar code labels.

2. Code Density and Dimensions

The bar heights shall be a minimum of 0.5". For each bar code symbol, the average width of narrow elements shall be within the range of .013 to .017 inches.

The ratio of the nominal width of the wide elements to the nominal width of the narrow elements shall be 3:1, with an allowable range of 2.8:1 to 3.2:1.

3. Check Digits

Check digits shall not be used in the bar codes.

17.6 Label Location and Protection

1. Label Locations

	<p>MEKRA Lang North America, LLC 101 Tillessen Boulevard Ridgeway, SC 29130</p>	<p>SD 7.4-51 Rev 7 Page 20 of 42</p>
<p>Support Document</p>	<p>SUPPLIER PACKAGING AND LABELING REQUIREMENTS</p>	<p>Approved By: Bhuvesh Dhir Revised By: Mauricio Alvarez Released By: Renee Tuttle Release Date: 2/22/2024</p>

Illustrations of the most common shipping packs and recommended label locations are shown in Exhibit L. The bottom edge of the label should be parallel to the base of the package/container. To facilitate automatic reading of the bar code symbols, the top edge of the label, whenever possible, should be 20” from the bottom of the container.

2. Label Protections

Label protection against moisture, weathering, abrasion, etc. may be required and is encouraged wherever practical. Laminates, sprays, window envelopes and clear plastic pouches are examples of possible protection methods. In choosing any protection method, care must be taken to assure that labels meet reflectivity and contrast requirements and can be scanned with contact and noncontact devices.

3. Separate Boxes

Each box even though on a master pallet requires individual labels. The individual labels are placed as shown in Exhibit C. This is for the purpose of lot tractability.

17.7 Special Labels

Special labels may be required for multiple and mixed item shipments. These labels should be used only when authorized by **MLNA/MLMX**.

1. Master Labels

A Master label, as shown in Exhibit P, shall be used when multiple packages of the same items are shipped together. The quantity listed on the Master Label shall be the total in all of the packages. Each individual package should be identified with a separate bar code label. The data identifier for the serial number shall be “M” instead of “S.”

2. Mixed Loads

A Mixed Load label, as shown in Exhibit Q, shall be used when packages of different items are shipped together. Each individual package should be identified with a separate bar code label. The data identifier for the serial number shall be “G” instead of “S.”

	<p>MEKRA Lang North America, LLC 101 Tillessen Boulevard Ridgeway, SC 29130</p>	<p>SD 7.4-51 Rev 7 Page 21 of 42</p>
<p>Support Document</p>	<p>SUPPLIER PACKAGING AND LABELING REQUIREMENTS</p>	<p>Approved By: Bhuvesh Dhir Revised By: Mauricio Alvarez Released By: Renee Tuttle Release Date: 2/22/2024</p>

18.0 Individual Piece Part Bar-Coding Requirements

18.1 General

These specifications, which apply to bar codes for individual piece parts or standard packs, were developed in conjunction with the TMC RP801C “Bar Code Guidelines.” For more information on TMC Standards, contact the Maintenance Council of the American Trucking Association, Director of Member Services at (703) 838-1761.

18.2 Quality

The use of bar code systems is intended to increase productivity and data accuracy within the automobile and truck manufacturing industries. Suppliers have the responsibility to provide bar code labels that meet the specifications of this document and those of the Bar Code Print Quality Guideline ANSI X3.182. It is recommended that verification audits be used in conjunction with statistical process control techniques to assure shipping label quality. The thermal printing method of bar coding generation is preferred by MLNA/MLMX due to the format flexibility and image quality.

18.3 Label, Size, Material, and Special Requirements

1. Label Size

The recommended label size is 1 inch high by 3 ½ inches wide.

2. Materials

The label paper should be white with black printing. Adhesive labels can be pressure sensitive or dry gummed as long as adherence to the part is assured and application is wrinkle-free.

3. Part Size Limitations

If the recommended 1 inch high by 3 ½ inch wide label cannot be adhered to the part due to the size, the part has to be tagged with the bar coded label or bagged with the bar coded label attached to the bag.

4. Individually Boxed Part

If a part is individually boxed, it is not necessary to place a 1-inch high by 3½-inch wide label on the part in addition to the box label. This individual piece part barcode information can be incorporated into the box label for individually boxed piece parts. The bar code specifications and

	<p>MEKRA Lang North America, LLC 101 Tillessen Boulevard Ridgeway, SC 29130</p>	<p>SD 7.4-51 Rev 7 Page 22 of 42</p>
<p>Support Document</p>	<p>SUPPLIER PACKAGING AND LABELING REQUIREMENTS</p>	<p>Approved By: Bhuvesh Dhir Revised By: Mauricio Alvarez Released By: Renee Tuttle Release Date: 2/22/2024</p>

human readable information (ref 17.3.1 Data Areas) must be included on each box label for parts individually packaged.

5. Standard Packs

For those parts **MLNA/MLMX**, distributes as a standard pack of greater than one, a bar code label will be required on the packaging for these parts and not on each individual part.

18.4 Label Information

1. Data Areas

The part number shall be displayed in both human readable characters and bar code symbols. The part description shall be displayed in human readable characters only. Human readable data characters shall be a minimum of 0.1” high. The part description shall be displayed above the bar code and the part number below the bar code (see examples in section 17.6).

2. Part Number

Part numbers shall be the same part numbers designated on the **MLNA/MLMX**'s Purchase Order/Scheduling Agreement or Material Release Authorization.

MLNA/MLMX's *Proprietary part number format (Note: ‘_’ denotes a space required in the bar code)*

Alpha Numeric Characters: 592704311-PDC

No Alpha Characters: 134142010

The maximum length of the part number shall be fifteen (15) alphanumeric characters.

3. Country of Origin

The country of origin must be clearly displayed on each label (as pictured) to meet custom requirements for international trade.

18.5 Bar Code Symbology

Bar Codes shall be the 3-of-9 (Code 39) type as specified by the TMC (RP801C).

1. Code Configurations

The four (4) characters (\$,/,+,%) of the 3-9 symbology shall not be used in the barcode labels.

2. Code Density and Dimensions

	<p>MEKRA Lang North America, LLC 101 Tillessen Boulevard Ridgeway, SC 29130</p>	<p>SD 7.4-51 Rev 7 Page 23 of 42</p>
<p>Support Document</p>	<p>SUPPLIER PACKAGING AND LABELING REQUIREMENTS</p>	<p>Approved By: Bhuvesh Dhir Revised By: Mauricio Alvarez Released By: Renee Tuttle Release Date: 2/22/2024</p>

The bar heights shall be a minimum of 3/16". For each bar code symbol, the average width of narrow elements shall be within the range of 0.013 to 0.017 inches. The ratio of nominal width of the wide elements to the nominal width of the narrow elements shall be 2:1.

3. Check Digits

Check digits shall not be used in the bar codes.

18.6 Approval of Bar Code Label by MLNA/MLMX

Prior to implementation of the bar coding requirement, the bar code shall be approved by MLNA/MLMX. Please submit a sample of each format you will be using to your Supplier Quality Engineer. When making a new PPAP submission, a full sized label is required with the submission.

19.0 New Product and Part Changes

19.1 Trial Parts

During the development process and ongoing product validations trial parts will be shipped from one location to another. For the reason to ensure that the parts get to the correct party, when shipping Trial Parts and parts for testing, the LM 799 (Exhibit P) form shall be used. Tags are to be on blue paper or labels. On boxes the labels are to be on all six sides of the box, like a dice. When the trial parts are being shipped as a pallet, the top five sides require the Trial parts label. When utilizing labels, all of the same information and format is required; the minimum size is 4"x5".

19.2 PPAP Samples

When shipping PPAP samples the PPAP Sample Tags LM 791. (Exhibit Q) Tags are to be printed on yellow paper or yellow labels. On boxes the labels are to be on all six sides of the box, like a dice. When the PPAP samples parts are being shipped as a pallet, the top five sides require the PPAP Sample parts label. When utilizing labels, all of the same information and format is required; the minimum size is 4"x5".

19.3 Safe Launch

Safe Launch applies to all production material suppliers. Safe Launch is to assure a smooth startup of a new part or modified process or new supplier. Safe Launch is required for all of the product prior to and through the first 30 days after MLNA/MLMX's SOP at a minimum. In the event that a supplier utilizes batch production and a single batch run when the batch run size exceeds 30 calendar days of demand; the first two batches require Safe Launch. The supplier inspection requirements are to conform with

	<p>MEKRA Lang North America, LLC 101 Tillessen Boulevard Ridgeway, SC 29130</p>	<p>SD 7.4-51 Rev 7 Page 24 of 42</p>
<p>Support Document</p>	<p>SUPPLIER PACKAGING AND LABELING REQUIREMENTS</p>	<p>Approved By: Bhuvesh Dhir Revised By: Mauricio Alvarez Released By: Renee Tuttle Release Date: 2/22/2024</p>

MLNA/MLMX standard packaging and labeling General Practices. If defects are discovered, the safe launch must reset to zero until zero defects are discovered. The intent is 30 days or two batches defect free to stop safe launch. For labeling, safe launch tags LM 798 (Exhibit R) are printed on green paper to be placed beside the bar code labels as shown in Exhibits C and L. When utilizing labels, all the same information and format is required; the minimum size is 4”x5”.

	<p>MEKRA Lang North America, LLC 101 Tillessen Boulevard Ridgeway, SC 29130</p>	<p>SD 7.4-51 Rev 7 Page 25 of 42</p>
<p>Support Document</p>	<p>SUPPLIER PACKAGING AND LABELING REQUIREMENTS</p>	<p>Approved By: Bhuvesh Dhir Revised By: Mauricio Alvarez Released By: Renee Tuttle Release Date: 2/22/2024</p>

20.0 Exhibits

EXHIBIT A, PLASTICS RECYCLING SYMBOLOGY

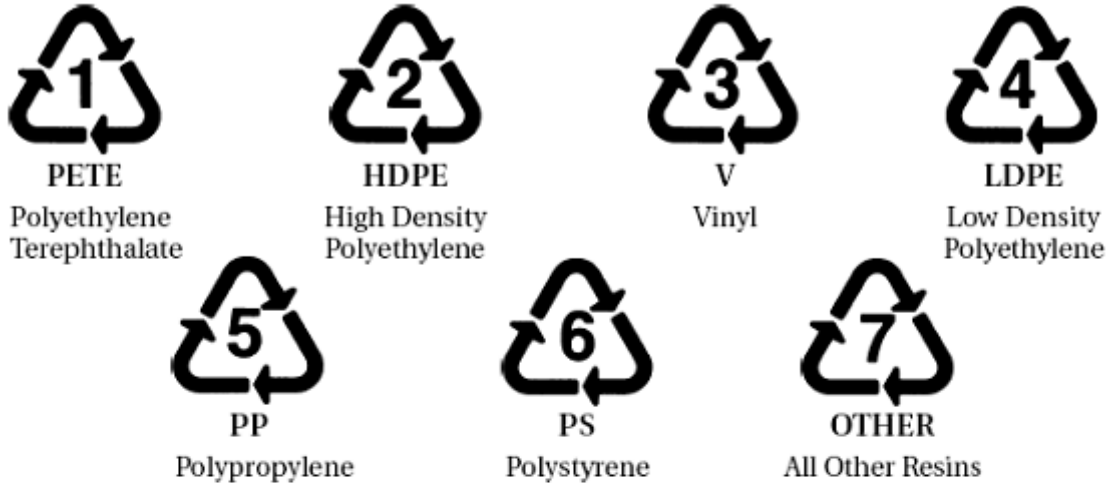

EXHIBIT B, CERTIFICATE OF BOX MANUFACTURER



	<p>MEKRA Lang North America, LLC 101 Tillessen Boulevard Ridgeway, SC 29130</p>	<p>SD 7.4-51 Rev 7 Page 26 of 42</p>
<p>Support Document</p>	<p>SUPPLIER PACKAGING AND LABELING REQUIREMENTS</p>	<p>Approved By: Bhuvesh Dhir Revised By: Mauricio Alvarez Released By: Renee Tuttle Release Date: 2/22/2024</p>

EXHIBIT C, TYPES OF EXPENDABLE CONTAINERS



Hand-Handled Container

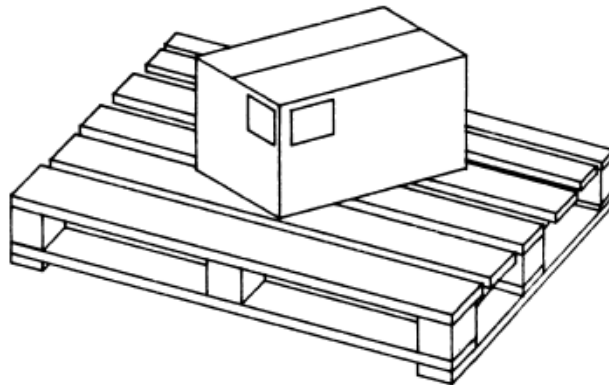
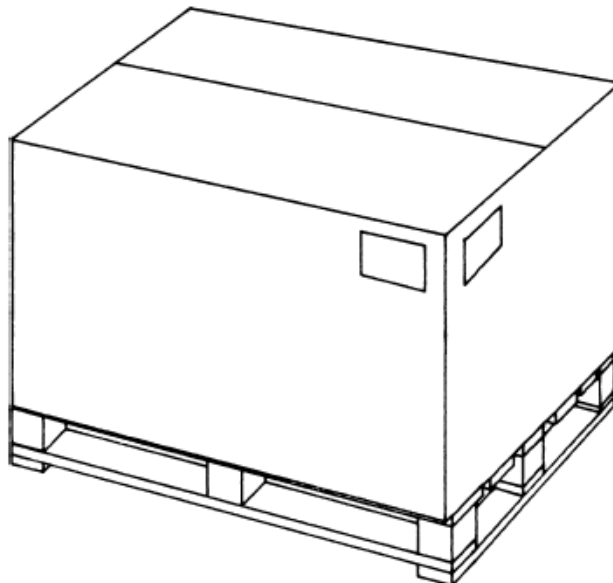

Mechanically-Handled Container

	<p>MEKRA Lang North America, LLC 101 Tillessen Boulevard Ridgeway, SC 29130</p>	<p>SD 7.4-51 Rev 7 Page 27 of 42</p>
<p>Support Document</p>	<p>SUPPLIER PACKAGING AND LABELING REQUIREMENTS</p>	<p>Approved By: Bhuvesh Dhir Revised By: Mauricio Alvarez Released By: Renee Tuttle Release Date: 2/22/2024</p>

EXHIBIT D, FIBERBOARD BOX SPECIFICATIONS

Maximum Weight Box/Contents (lbs.)	Maximum Outside Dimension (L+W+D)	Minimum Burst Test Single Wall, Double Wall, or Solid Fiber Board (lbs. per sq. in.) or Minimum Puncture Test Triple Wall Board (in oz. per in. tear)	Minimum Combined Weight of Facings, Including Center Facing(s) of Double Wall and Triple Wall Board or Minimum Combined Weight of Plies, Solid Fiberboard (lbs per 1000 sf)	Minimum Edge Crush Test (lbs per in width)
SINGLE WALL CORRUGATED FIBERBOARD BOXES				
20	40	125	52	23
35	50	150	66	26
50	60	175	75	29
65	75	200	84	32
80	85	250	111	40
95	95	275	138	44
120	105	350	180	55
DOUBLE WALL CORRUGATED FIBERBOARD BOXES				
80	85	200	92	42
100	95	275	110	48
120	105	350	126	51
140	110	400	180	61
160	115	500	222	71
180	120	600	270	82
TRIPLE WALL CORRUGATED FIBERBOARD BOXES				
240	110	700	168	67
260	115	900	222	80
280	120	1100	264	90
300	125	1300	360	112
SOLID FIBERBOARD BOXES				
20	40	125	114	N/A
40	60	175	149	N/A
65	75	200	190	N/A
90	90	275	237	N/A
120	100	350	283	N/A

	<p>MEKRA Lang North America, LLC 101 Tillessen Boulevard Ridgeway, SC 29130</p>	<p>SD 7.4-51 Rev 7 Page 28 of 42</p>
<p>Support Document</p>	<p>SUPPLIER PACKAGING AND LABELING REQUIREMENTS</p>	<p>Approved By: Bhuvesh Dhir Revised By: Mauricio Alvarez Released By: Renee Tuttle Release Date: 2/22/2024</p>

EXHIBIT E, BULK CONTAINER CONSTRUCTION

The Fiber Corner Supports are Designed for Recyclability



Spiral Wound Tube

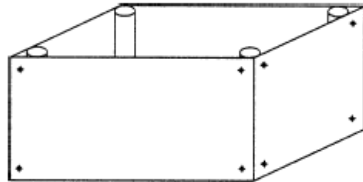
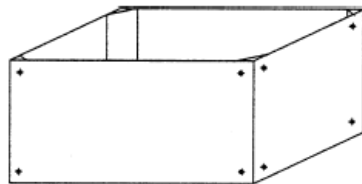
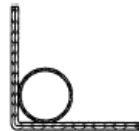

Corrugated Insert

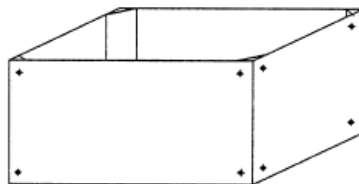
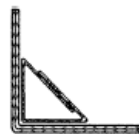

Preformed Fiber Inserts

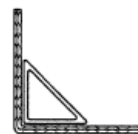

Break-Away Feature for Bulk Containers

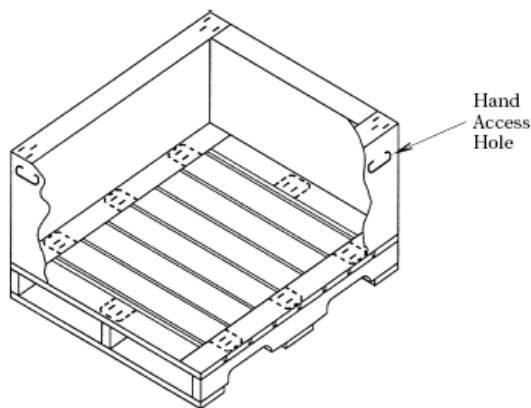

The carton is attached to the pallet by stapling within the perforated areas as shown. When disassembled, the carton easily separates from the pallet at the perforations.

	<p>MEKRA Lang North America, LLC 101 Tillessen Boulevard Ridgeway, SC 29130</p>	<p>SD 7.4-51 Rev 7 Page 29 of 42</p>
<p>Support Document</p>	<p>SUPPLIER PACKAGING AND LABELING REQUIREMENTS</p>	<p>Approved By: Bhuvesh Dhir Revised By: Mauricio Alvarez Released By: Renee Tuttle Release Date: 2/22/2024</p>

EXHIBIT F, TYPES OF WOOD PALLETS

Notched Stringer Design—Flush Type

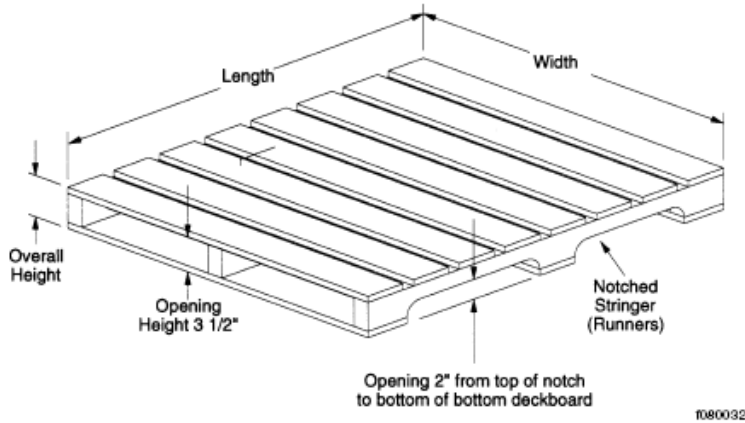

Exhibit G - Removed

	<p>MEKRA Lang North America, LLC 101 Tillessen Boulevard Ridgeway, SC 29130</p>	<p>SD 7.4-51 Rev 7 Page 30 of 42</p>
<p>Support Document</p>	<p>SUPPLIER PACKAGING AND LABELING REQUIREMENTS</p>	<p>Approved By: Bhuvesh Dhir Revised By: Mauricio Alvarez Released By: Renee Tuttle Release Date: 2/22/2024</p>

EXHIBIT H, STRENGTH OF CORRUGATED CARTONS

These examples demonstrate the potential loss in top-to-bottom compression strength when corrugated cartons are stacked improperly or under adverse conditions.

% Loss in Compression Strength

Pallet/Carton Overhang

Up to 32%

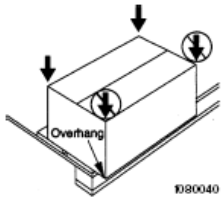

Interlocked Stacking Pattern

Up to 50%

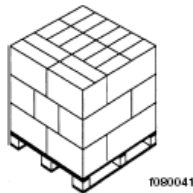

Carton Misalignment

Up to 30%

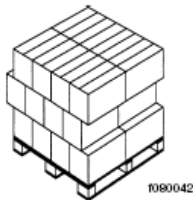

Long-Term Storage

Up to 50%

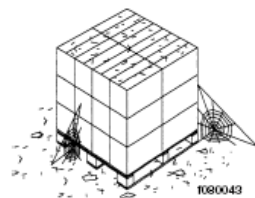

High Humidity (90% RH)

Up to 60%

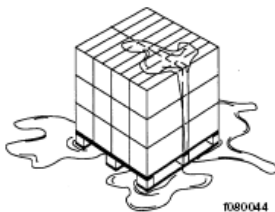

	<p>MEKRA Lang North America, LLC 101 Tillessen Boulevard Ridgeway, SC 29130</p>	<p>SD 7.4-51 Rev 7 Page 31 of 42</p>
<p>Support Document</p>	<p>SUPPLIER PACKAGING AND LABELING REQUIREMENTS</p>	<p>Approved By: Bhuvesh Dhir Revised By: Mauricio Alvarez Released By: Renee Tuttle Release Date: 2/22/2024</p>

EXHIBIT I, LOADING OF CARTONS

Examples of Properly Palletized Cartons



Acceptable

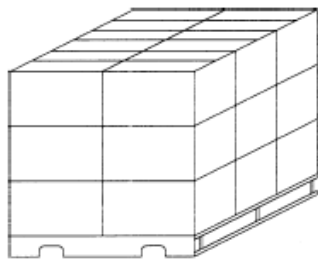
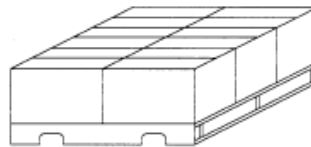

Acceptable

1080030

Examples of "Pyramided" Cartons

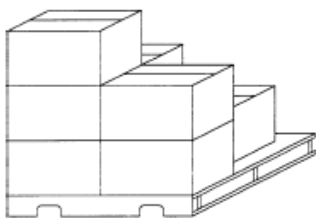

Unacceptable

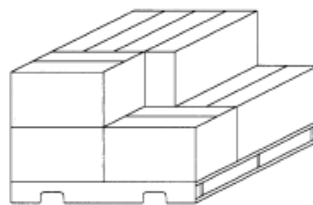

Unacceptable

1080031

	<p>MEKRA Lang North America, LLC 101 Tillessen Boulevard Ridgeway, SC 29130</p>	<p>SD 7.4-51 Rev 7 Page 32 of 42</p>
<p>Support Document</p>	<p>SUPPLIER PACKAGING AND LABELING REQUIREMENTS</p>	<p>Approved By: Bhuvesh Dhir Revised By: Mauricio Alvarez Released By: Renee Tuttle Release Date: 2/22/2024</p>

EXHIBIT J, MIXED LOAD PROCEDURE

The following example illustrates when it is acceptable to ship different part numbers on the same pallet.

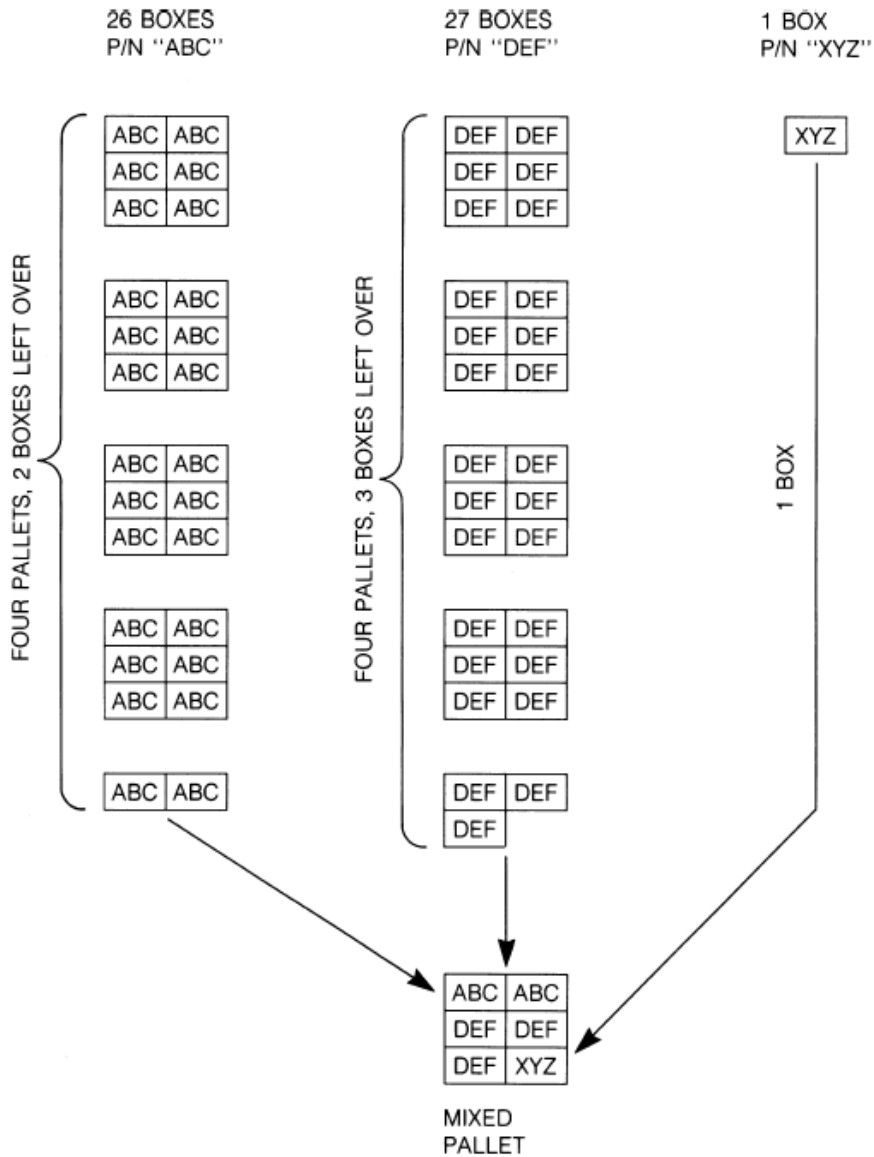

	<p>MEKRA Lang North America, LLC 101 Tillessen Boulevard Ridgeway, SC 29130</p>	<p>SD 7.4-51 Rev 7 Page 33 of 42</p>
<p>Support Document</p>	<p>SUPPLIER PACKAGING AND LABELING REQUIREMENTS</p>	<p>Approved By: Bhuvesh Dhir Revised By: Mauricio Alvarez Released By: Renee Tuttle Release Date: 2/22/2024</p>

EXHIBIT K, LABEL DIMENSIONS



	<p>MEKRA Lang North America, LLC 101 Tillessen Boulevard Ridgeway, SC 29130</p>	<p>SD 7.4-51 Rev 7 Page 34 of 42</p>
<p>Support Document</p>	<p>SUPPLIER PACKAGING AND LABELING REQUIREMENTS</p>	<p>Approved By: Bhuvesh Dhir Revised By: Mauricio Alvarez Released By: Renee Tuttle Release Date: 2/22/2024</p>

EXHIBIT L, LABEL LOCATIONS

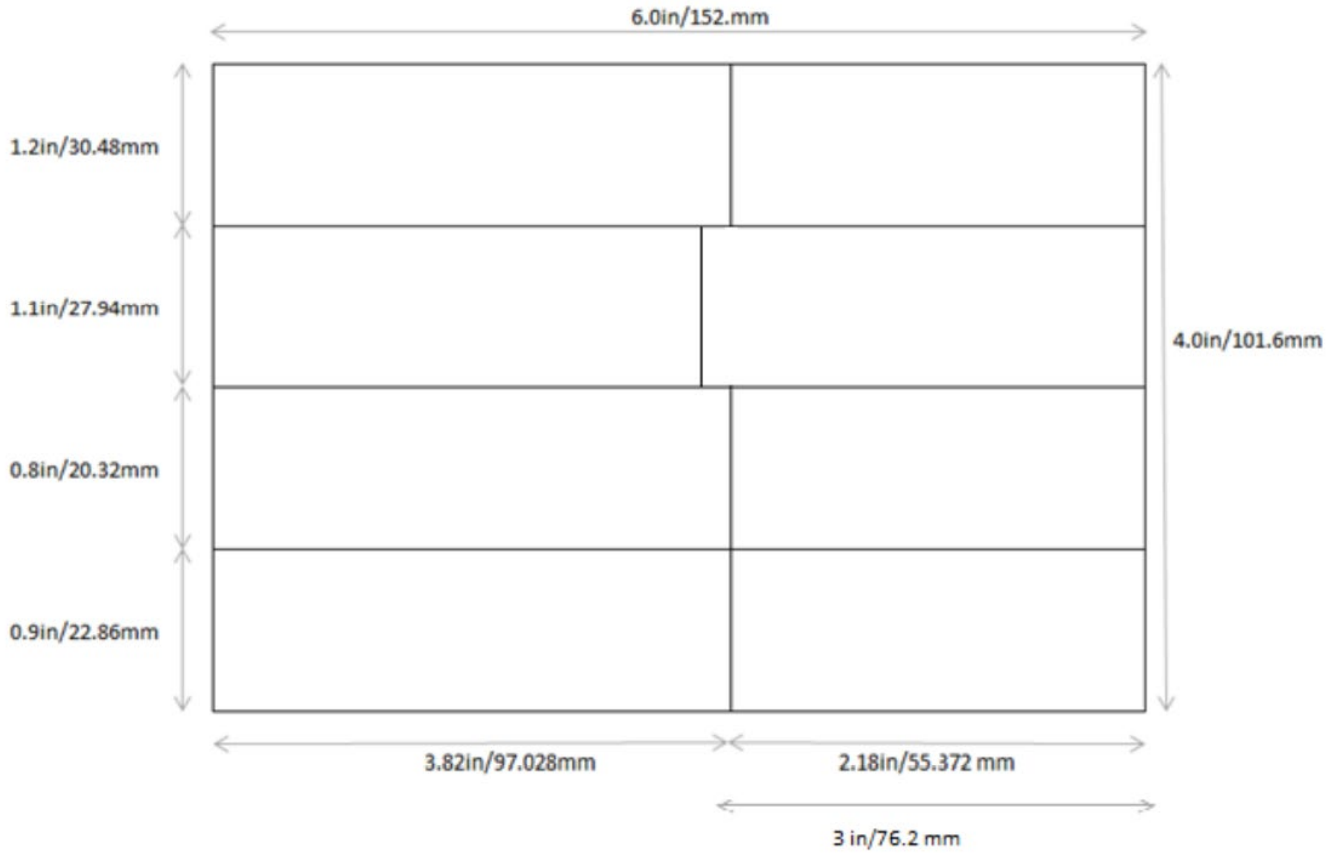

Box or Carton

Identical labels should be located on two adjacent sides. (Wrap around label acceptable.) The upper edges of the labels should be as high as possible up to 20" from the bottom of carton.

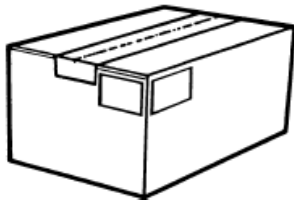
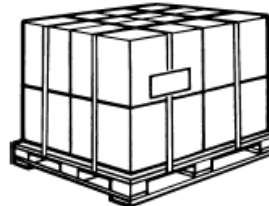

Cartons on Pallet

One master label may be used as described in section 16.7.1, or one mixed load label as described in section 16.7.2.

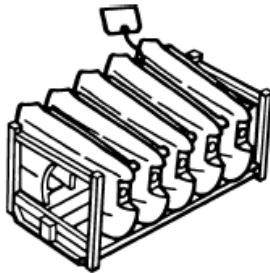

Rack

Tag one visible piece near top, or use a label holder.

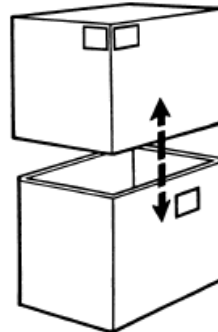

Telescopic or Set-up Containers

Identical labels should be located on two adjacent sides of the outer box. Some applications may also require identification of the inner box.

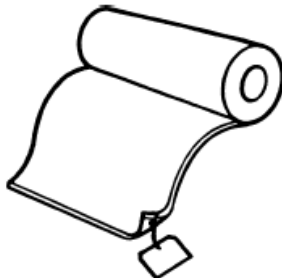

Roll

Hand one tag 2" (51 mm) from end of the material.



Bundle

Identical tags should be located at each end.

	MEKRA Lang North America, LLC 101 Tillessen Boulevard Ridgeway, SC 29130	SD 7.4-51 Rev 7 Page 35 of 42
Support Document	SUPPLIER PACKAGING AND LABELING REQUIREMENTS	Approved By: Bhuvesh Dhir Revised By: Mauricio Alvarez Released By: Renee Tuttle Release Date: 2/22/2024

EXHIBIT M, BAR CODED SHIPPING LABEL

PART NUMBER (P) 703HX 	Revision (R) A 
QUANTITY (Q) 1 EA 	P.O. (K) 210900123456 
SUPPLIER (V) 65600 	LOCATION (L) SP-SM-X-6 
SERIAL (S4) 881348  SUPPLIER NAME (SN) XYZ SUPPLY CITY / ST / ZIP	SHIP DATE (SD) MFG DATE (MD) Manufacturing Lot No (ML) Country of Origin (CO)

	MEKRA Lang North America, LLC 101 Tillessen Boulevard Ridgeway, SC 29130	SD 7.4-51 Rev 7 Page 36 of 42
Support Document	SUPPLIER PACKAGING AND LABELING REQUIREMENTS	Approved By: Bhuvesh Dhir Revised By: Mauricio Alvarez Released By: Renee Tuttle Release Date: 2/22/2024

EXHIBIT N, BAR CODED SHIPPING TAG

PART NUMBER (P) 703HX 	Revision (R) A 
QUANTITY (Q) 1 EA 	P.O. (K) 210900123456 
SUPPLIER (V) 65600 	LOCATION (L) SP-SM-X-6 
SERIAL (S4) 881348  SUPPLIER NAME (SN) XYZ SUPPLY CITY / ST / ZIP	SHIP DATE (SD) MFG DATE (MD) Manufacturing Lot No (ML) Country of Origin (CO)

	<p style="text-align: center;">MEKRA Lang North America, LLC 101 Tillessen Boulevard Ridgeway, SC 29130</p>	<p>SD 7.4-51 Rev 7 Page 37 of 42</p>
<p style="text-align: center;">Support Document</p>	<p style="text-align: center;">SUPPLIER PACKAGING AND LABELING REQUIREMENTS</p>	<p>Approved By: Bhuvesh Dhir Revised By: Mauricio Alvarez Released By: Renee Tuttle Release Date: 2/22/2024</p>

EXHIBIT O, UNIT OF MEASURE ABBREVIATIONS

Code Definition

Distance

DK Kilometers
MI Miles

Number of Units

NB Barge
NC Car
NL Load
NN Train
NR Container
NT Trailer
NV Vehicle
PC Piece

Temperature

CE Centigrade, Celsius
FA Fahrenheit
KV Kelvin

Time

DA Days
HR Hours
LH Labor Hours
MO Months
WK Week
YR Years

Unit of Sale

AM Ampoule
AY Assembly
BA Bale
BB Base Box
BC Bucket
BD Bundle
BE Beam
BF Board Feet
BG Bag
BH Brush
BI Bar
BK Book
BL Block
BN Bulk
BO Bottle
BR Barrel
BT Belt
BU Bushel
BX Box
CA Case
CB Carboy
CC Cubic Centimeter
CF Cubic Feet
CG Card
CH Container
CI Cubic Inches
CJ Cone
CK Connector
CL Cylinder
CM Centimeter
CN Can
CO Coil
CP Crate

Code Definition

Unit of Sale (Cont.)

CQ Cartridge
CR Cubic Meter
CS Cassette
CT Carton
CU Cup
CV Cover
CW Hundred Pounds (CWT)
CY Cubic Yards
CZ Combo
DC Disk (Disc)
DE Deal
DG Decigram
DM Decimeter
DR Drum
DS Display
DZ Dozen
EA Each
EV Envelope
FT Foot
GA Gallon
GR Gram
GS Gross
HD One-Half Dozen
HU Hundred
IN Inch
JB Jumbo
JO Joint
JR Jar
KE Keg
KG Kilogram
KH Hilowatt Hour
KT Kit
LB Pound
LC Linear Centimeter
LF Linear Foot
LG Long Ton
LI Linear Inch
LK Link
LM Linear Meter
LN Length
LO Lot
LP Liquid Pounds
LT Liter
LY Linear Yard
MA Machine/Unit
MC Microgram
MG Metric Gross Ton
ML Milligram
MM Millimeter
MN Metric Net Ton
MR Meter
MS Square Millimeter
MT Metric Long Ton
MX Mixed
OL Ounce—Liquid
OZ Ounce AV
PA Pail
PC Piece
PD Pad
PE Pounds Equivalent
PF Pallet (Lift)
PG Pounds Gross
PH Pack (PAK)

Code Definition

Unit of Sale (Cont.)

PK Package
PL Pallet/Unit Load
PN Pounds Net
PR Pair
PT Pint
PW Pennyweight
QD Quarter Dozen
QR Quire
QT Quart
RD Rod
RE Reel
RL Roll
RM Ream
SA Sandwich
SC Square Centimeter
ST Set
SF Square Foot
SG Segment
SH Sheet
SI Square Inch
SL Sleeve
SM Square Meter
SO Spool
SQ Square
SR Strip
SY Square Yard
TB Tube
TG Gross Ton
TH Thousand
TK Tank
TN Net Ton
TO Troy Ounce
TY Tray
UN Unit
WH Wheel
YD Yard
ZZ Mutually Defined

Value

CS Cost
LS Lump Sum
MV Monetary Value

Volume

DL Deciliter
DM Dram
FO Fluid Ounce
GA Gallon
LT Liter
ML Milliliter
PT Pint
QT Quart

Other

ZZ Mutually Devined

	MEKRA Lang North America, LLC 101 Tillessen Boulevard Ridgeway, SC 29130	SD 7.4-51 Rev 7 Page 38 of 42
Support Document	SUPPLIER PACKAGING AND LABELING REQUIREMENTS	Approved By: Bhuvesh Dhir Revised By: Mauricio Alvarez Released By: Renee Tuttle Release Date: 2/22/2024

EXHIBIT P, MASTER LABEL

<h1>MASTER LABEL</h1>	
PART NUMBER (P) 703HX 	Revision (R) A 
QUANTITY (Q) 1 EA 	P.O. (K) 210900123456 
SUPPLIER (V) 65600 	LOCATION (L) SP-SM-X-6 
SERIAL (S4) 881348  SUPPLIER NAME (SN) XYZ SUPPLY CITY / ST / ZIP	SHIP DATE (SD) MFG DATE (MD) Manufacturing Lot No (ML) Country of Origin (CO)

	<p>MEKRA Lang North America, LLC 101 Tillessen Boulevard Ridgeway, SC 29130</p>	<p>SD 7.4-51 Rev 7 Page 39 of 42</p>
<p>Support Document</p>	<p>SUPPLIER PACKAGING AND LABELING REQUIREMENTS</p>	<p>Approved By: Bhuvesh Dhir Revised By: Mauricio Alvarez Released By: Renee Tuttle Release Date: 2/22/2024</p>

EXHIBIT Q, MIXED LOAD LABEL



	<p>MEKRA Lang North America, LLC 101 Tillessen Boulevard Ridgeway, SC 29130</p>	<p>SD 7.4-51 Rev 7 Page 40 of 42</p>
<p>Support Document</p>	<p>SUPPLIER PACKAGING AND LABELING REQUIREMENTS</p>	<p>Approved By: Bhuvesh Dhir Revised By: Mauricio Alvarez Released By: Renee Tuttle Release Date: 2/22/2024</p>

Exhibit P – Form LM 799 Trial Parts Tag

Trial Parts

Attn.: _____

Part Number _____

Revision _____

Quantity _____

Supplier _____

Trial Purpose _____

LM 799 Rev 1 – New release
Cut Here Cut Here Cut Here Cut Here Cut Here Cut Here

To be applied to all six sides of the box and all five showing sides of a pallet
Cut Here Cut Here Cut Here **PRINT ON BLUE PAPER** Here Cut Here Cut Here Cut Here
Cut Here

	MEKRA Lang North America, LLC 101 Tillessen Boulevard Ridgeway, SC 29130	SD 7.4-51 Rev 7 Page 41 of 42
Support Document	SUPPLIER PACKAGING AND LABELING REQUIREMENTS	Approved By: Bhuvesh Dhir Revised By: Mauricio Alvarez Released By: Renee Tuttle Release Date: 2/22/2024

Exhibit Q – Form LM 791 PPAP Sample Tag

PPAP Sample

Attn.:

Part Number

Revision

Quantity

Supplier

LM 791 Rev 2
 Cut Here Cut Here Cut Here Cut Here Cut Here Cut Here

To be applied to all six sides of the box and all five showing sides of a pallet
 Cut Here Cut Here Cut **PRINT ON YELLOW PAPER** Cut Here Cut Here Cut Here Cut Here

	MEKRA Lang North America, LLC 101 Tillessen Boulevard Ridgeway, SC 29130	SD 7.4-51 Rev 7 Page 42 of 42
Support Document	SUPPLIER PACKAGING AND LABELING REQUIREMENTS	Approved By: Bhuvesh Dhir Revised By: Mauricio Alvarez Released By: Renee Tuttle Release Date: 2/22/2024

Exhibit R – Form LM 799 Safe Launch Tag

Safe Launch Parts

Part Number _____

Revision _____

Quantity _____

Supplier _____

Certified By _____

Date _____

LM 798 Rev. 1
 Cut Here Cut Here Cut Here Cut Here Cut Here Cut Here
 To be applied besides Bar Code Label on each box and To be applied besides Master Pallet Label on each pallet
 Cut Here Cut Here PRINT ON GREEN PAPER Cut Here Cut Here Cut Here Cut Here Cut Here

	<p style="text-align: center;">MEKRA Lang North America, LLC 101 Tillessen Boulevard Ridgeway, SC 29130</p>	<p>CP 045 Rev # 2 Page 1 of 7</p>
<p style="text-align: center;">Policy</p>	<p style="text-align: center;">CODE OF CONDUCT</p>	<p>Approved By: Jasmin Fonce Revised By: Jasmin Fonce Released By: Renee Tuttle Release Date: 10/26/2020</p>

As a family business, we know that our continued success hinges on the support and cooperation of our employees and business partners and is based on our common values. It is only by letting these values guide us in everything we do, and treating each other and our business partners with respect, that we will be able to sustain the success of the MEKRA Lang Group as a leading manufacturer of vision systems. We have developed this code of conduct to show how our values influence the work we do every day and to provide all MEKRA Lang employees with binding guidelines for their daily activities. Let us abide by this code of conduct both inside and outside of our company to support each other in living our values and treating each other with fairness and respect.

Your MEKRA Lang Group Leadership Team

PRINCIPLES

Law-Abiding Conduct

We affirm the principle of legality and pledge that any actions, measures, agreements, and other procedures of the MEKRA Lang Group will be implemented in strict compliance with applicable laws and legal regulations. Each employee is personally responsible for complying with the law in his or her specific field. We will not cause third parties to engage in unlawful activities or knowingly participate in such activities.

Management personnel must ensure that there are no violations of legal regulations or this code of conduct in their areas of responsibility which could have been avoided by proper supervision. They must make clear that infringements are unacceptable and will lead to disciplinary action, regardless of the rank or status of the infringing party within the company.

Responsibility for the Reputation of the MEKRA Lang Group

All employees are required to uphold the reputation of the MEKRA Lang Group when performing their duties. Each employee must hold himself or herself personally accountable for protecting the good name of the company as a whole, as the conduct of every single employee affects our image and reputation within the larger community.

HUMAN RIGHTS

As a global player, the MEKRA Lang Group is firmly committed to meeting its social and societal responsibilities. Above all, we are committed to upholding human rights, as defined in Article I of the United Nations' Universal Declaration of Human Rights:

"All human beings are born free and equal in dignity and rights", and as amended by Article 29.1 which reads: "Everyone has duties to the community in which alone the free and full development of his personality is possible".

	<p style="text-align: center;">MEKRA Lang North America, LLC 101 Tillessen Boulevard Ridgeway, SC 29130</p>	<p>CP 045 Rev # 2 Page 2 of 7</p>
<p style="text-align: center;">Policy</p>	<p style="text-align: center;">CODE OF CONDUCT</p>	<p>Approved By: Jasmin Fonce Revised By: Jasmin Fonce Released By: Renee Tuttle Release Date: 10/26/2020</p>

As management team, we are doing our utmost to create a community whose rules respect and uphold these inalienable human rights, as well as an environment in which our employees can develop their talents and personalities freely and flourish professionally. Based on these value-driven management principles and in consideration of the Universal Declaration of Human Rights, the fundamental principles of the International Labor Organization (ILO), and the applicable laws in various countries and locations, as well as in recognition and support of cultural differences, we pledge to abide by the following principles:

a. Treatment of Employees

We respect and protect every individual's personal dignity. Any form of discrimination and harassment will not be tolerated at any of the MEKRA Lang Group's locations. We are committed to respecting the fundamental rights of all employees, including without limitation:

I: Equal opportunities and non-discrimination for all employees, regardless of color, race, nationality, social background, disability, sexual orientation, political or religious convictions, gender, or age.

II: Respect for each individual's personal dignity, privacy, and personality rights.

III: No forced employment or forced labor

IV: Zero tolerance for unacceptable treatment of personnel, such as mental cruelty, sexual and personal harassment or discrimination.

V: Zero tolerance for sexually coercive, threatening, abusive, or exploitative behavior.

VI: Appropriate compensation and the payment of nationally applicable legal minimum wages.

VII: Compliance with any nationally or locally applicable legal limits on working hours.

b. Child Labor and Forced Labor

It is of particular importance to us to state that we will not tolerate and will take action against any case of child labor and forced labor, including at our business partners' locations. Child labor is prohibited according to ILO and UN conventions and/or national laws. Of these different standards the one with the most stringent requirements shall apply. Any form of child exploitation is prohibited. Working conditions which resemble those of slavery or which endanger the health of children are prohibited.

The rights of young employees are to be protected. Should children be found in situations which fulfil the definition of child labor as stipulated by the above standards, the supplier must take appropriate remedial action and provide the corresponding supporting documentation.

Additionally, the supplier must support said children adequately to ensure their ability to attend school during their childhood years.

	<p style="text-align: center;">MEKRA Lang North America, LLC 101 Tillessen Boulevard Ridgeway, SC 29130</p>	<p>CP 045 Rev # 2 Page 3 of 7</p>
<p style="text-align: center;">Policy</p>	<p style="text-align: center;">CODE OF CONDUCT</p>	<p>Approved By: Jasmin Fonce Revised By: Jasmin Fonce Released By: Renee Tuttle Release Date: 10/26/2020</p>

Any non-compliance with these rules entitles the MEKRA Lang Group, after granting a reasonable period of time for rectifying the situation, to terminate the contractual relationship for cause. Child protection measures at the MEKRA Lang Group are based on the following definitions:

Definition of a Child:

A person under the age of 15, unless applicable local minimum-age laws stipulate a higher age for gainful employment or compulsory schooling, in which case the higher age shall apply. If, however, the local minimum age is set to 14 years according to the exceptions for developing countries stipulated in ILO Convention No. 138, such lower minimum age is applicable.

Definition of a Young Person:

A worker who is older than a child according to the above definition, but younger than 18 years.

Definition of Child Labor:

Work performed by a child or a young person under the minimum age as defined above which does not comply with the provisions of the relevant ILO standards. Child labor is defined as work which deprives children of their childhood, robs them of their potential and their dignity and is detrimental to their mental and physical development.

The definition applies to work which is mentally, physically, socially and morally dangerous and harmful to children, deprives them of or limits their opportunity to attend school, obliges them to leave school prematurely, or requires them to attempt to combine school attendance with excessively long and hard work. Work which, by its nature or the circumstances in which it is carried out, is likely to harm the health, safety or morals of children.

c. Occupational Health and Safety, Fire Prevention and Environmental Protection

All employees are responsible for avoiding situations which pose risks to people and the environment, for minimizing the environmental impact and for using resources sparingly.

Processes, facilities and supplies must meet all applicable legal and company requirements concerning occupational health and safety, fire prevention and environmental protection. Occupational health and safety as well as humane working conditions represent essential aspects of our company policies.

The foregoing particularly applies to the provision and use of personal protective gear, clean restrooms and access to drinking water. In some situations, facilities for hygienic food storage must also be provided. Practices and workplace conditions which violate basic human rights are prohibited. Above all, young employees must not be exposed to hazardous, unsafe or unhealthy conditions.

Any non-compliance with the above rules entitles the MEKRA Lang Group to terminate the contractual relationship for cause.

	<p style="text-align: center;">MEKRA Lang North America, LLC 101 Tillessen Boulevard Ridgeway, SC 29130</p>	<p>CP 045 Rev # 2 Page 4 of 7</p>
<p style="text-align: center;">Policy</p>	<p style="text-align: center;">CODE OF CONDUCT</p>	<p>Approved By: Jasmin Fonce Revised By: Jasmin Fonce Released By: Renee Tuttle Release Date: 10/26/2020</p>

d. No Forced Labor and Disciplinary Measures

All forms of forced labor are prohibited, including those effected by requiring a deposit or withholding employees' identification papers at the outset of the employment relationship.

Prison labor which violates basic human rights is also prohibited. Corporal punishment as well as mental or physical coercion and verbal abuse are equally prohibited. Any non-compliance with these rules entitles the MEKRA Lang Group to terminate the contractual relationship for cause.

HANDLING OF INFORMATION

a. Reporting

All of our records, reports and announcements must be accurate and true. The principles of proper accounting and bookkeeping must be adhered to at all times. Data collection as well as other types of record keeping must be complete, accurate, timely and well organized.

Using the company's confidential information for the creation of records, files, and similar items is not permissible, unless it serves the interests of the MEKRA Lang Group directly and is performed in accordance with all applicable data protection standards.

b. Data Protection and Information Security

When designing and performing any business processes (including those based on IT), the protection of personality rights as well as privacy and information security must be ensured based on and in accordance with all applicable legal requirements and operating procedures relating to data protection, IT and data security. Each employee of the MEKRA Lang Group is required to protect confidential information from misuse or dissemination.

Confidential information is defined as any non-public information, including but not limited to any trade secrets of the MEKRA Lang Group, business plans, marketing campaigns, product development information, inventions, manufacturing procedures, employee data, compensation information, medical records and business results. Confidential information entrusted to the MEKRA Lang Group by third parties must be handled with the same amount of care as is afforded to MEKRA Lang Group's own confidential information.

Specifically, personal data (of customers, suppliers, employees or other affected persons) collected, processed or transmitted in connection with business processes within the European Union (EU) and the European Economic Area (EEA) is subject to the applicable data protection regulations.

c. Non-Disclosure

The company's confidential information must not be disclosed. This obligation shall survive the termination of the employment relationship. Should the disclosure of information be required to ensure

	<p style="text-align: center;">MEKRA Lang North America, LLC 101 Tillessen Boulevard Ridgeway, SC 29130</p>	<p>CP 045 Rev # 2 Page 5 of 7</p>
<p style="text-align: center;">Policy</p>	<p style="text-align: center;">CODE OF CONDUCT</p>	<p>Approved By: Jasmin Fonce Revised By: Jasmin Fonce Released By: Renee Tuttle Release Date: 10/26/2020</p>

the proper conduct of business, every effort must be made to ensure that said information is evaluated regarding its non-disclosure requirements, as stipulated by current company policies, and protected accordingly (e.g. by means of a non-disclosure agreement).

Each employee must abide by all applicable rules and legal regulations relating to fair competition. Specifically, competitors must refrain from any division of sales territories or customer allocations, and from agreements or exchange of information on prices/price elements, supplier relationships or terms and conditions of any kind as well as capacities or bidding approaches.

The same applies to the exchange of information on market and investment strategies. As a matter of principle, neither written or verbal agreements, nor any tacit, conscious parallel behavior concerning these matters are permissible.

Agreements with customers and suppliers which are intended to limit customers' freedom to independently determine their resale prices or other terms and conditions are not allowed.

BUSINESS ACTIVITIES

a. Supplier and Customer Relationships

Any agreement concluded with customers and suppliers must exclusively serve the interests of the company. Each employee is required to abide by the applicable internal control rules (e.g. dual control principle). Supplier selection must be based solely on competitive factors, after careful consideration of pricing, quality, performance, company strategy and suitability of the products and services offered.

b. Bribery, Gifts, and other Gratuities

Agreements or subsidiary agreements relating to the acceptance or granting of advantages by or to individuals in connection with any order procurement, placement, delivery, processing, and payment are not permissible. Any attempt by suppliers or customers to improperly influence employees of the MEKRA Lang Group in their decision-making must be reported to the appropriate supervisor or manager. Commissions and compensation paid to authorized dealers, sales representatives, or consultants must be reasonably and justifiably proportionate to their performance. No benefits may be agreed upon which, as a whole or in part, could be reasonably assumed to be intended as bribes.

Accepting and giving gifts and other gratuities (such as participation in events which are not directly business-related), including invitations (of and by suppliers or customers), must be handled in an extremely restrictive manner. Financially, these must be limited to amounts which the recipient can openly acknowledge and which do not force him or her into a position of dependence.

When in doubt, written approval of the appropriate supervisor or manager should be obtained. In your capacity as an employee, you must at all times act in the interest of the MEKRA Lang Group and avoid any conflicts of interest.

	<p style="text-align: center;">MEKRA Lang North America, LLC 101 Tillessen Boulevard Ridgeway, SC 29130</p>	<p>CP 045 Rev # 2 Page 6 of 7</p>
<p style="text-align: center;">Policy</p>	<p style="text-align: center;">CODE OF CONDUCT</p>	<p>Approved By: Jasmin Fonce Revised By: Jasmin Fonce Released By: Renee Tuttle Release Date: 10/26/2020</p>

c. Company Assets

All business and capital assets of the MEKRA Lang Group may be used for business purposes only. They may not be used for personal ends, fraudulent intentions or other similarly inappropriate purposes. This applies to both tangible and intangible assets (such as patents, know-how, trademarks, data processing systems, etc.).

d. Conflicts of Interest

A conflict of interest is created, when your private interests, personal relationships, or activities outside of the company influence you, or create the impression of influencing you, in performing your professional duties.

Any gifts of any kind received by employees in their capacity as MEKRA Lang Group personnel must be handed over to management without exception. In most cases, these items will be entered into the annual raffle which is open to all employees and ensures the equal treatment of all employees.

CORPORATE RESPONSIBILITY

As an integral part of the larger society, we are aware of our corporate responsibility. The MEKRA Lang Group of companies supports educational, scientific, cultural, and social causes through financial and in-kind donations. The allocation of such donations is solely determined by management and must be based on altruistic motives.

Product Quality and Safety

Our slogan “Passion for Excellence” refers to our goal of meeting our customers' high quality and safety expectations. Any improvements helping us to achieve this goal will be implemented thoroughly and sustainably.

Should defects occur despite our best efforts, we will take the appropriate corrective action in accordance with legal requirements and contractual obligations, always placing the highest priority on the prevention of dangers to life and limb.

Reporting of Irregularities

The rules stipulated in this code of conduct form a central part of the company values we all live by. Each employee must do everything in his or her power to ensure that these values are adhered to uniformly throughout the Group.

Supervisors and managers have a special responsibility to lead by example and to communicate the contents of this code of conduct by the way they comport themselves. Each employee is entitled to bring to the attention of his or her supervisor or the HR department any circumstances which may point to a

	<p style="text-align: center;">MEKRA Lang North America, LLC 101 Tillessen Boulevard Ridgeway, SC 29130</p>	<p>CP 045 Rev # 2 Page 7 of 7</p>
<p style="text-align: center;">Policy</p>	<p style="text-align: center;">CODE OF CONDUCT</p>	<p>Approved By: Jasmin Fonce Revised By: Jasmin Fonce Released By: Renee Tuttle Release Date: 10/26/2020</p>

violation of the regulations contained herein; where appropriate, this may be done anonymously. These notifications will be investigated and any necessary remedial action will be taken.

If you are not sure about how to handle a certain situation, or if you wish to report a violation of this code of conduct, please send an email to info@mekra.de.

At any time, relevant information may be submitted to the HR department via its mailbox or to the supervisor using interoffice mail (where appropriate, this may be done anonymously).

Environmental Protection

As our corporate philosophy is based on the principle of sustainable growth, we have always championed an energy-efficient and eco-friendly utilization of resources. We are committed to upholding the principles of environmental protection in accordance with legal regulations and international standards, and pledge to implement management systems which reduce the utilization of resources and environmental burdens in a continuous and transparent manner.

Additionally, we apply the latest technologies and standards to lead by example when it comes to environmental protection, even taking on a pioneering role in some selected areas.

Monitoring

Each MEKRA Lang Group company is responsible for ensuring that the rules and regulations contained in this code of conduct as well as other internal company rules are followed within their area of responsibility. As a family business, we know that our continued success hinges on the support and cooperation of our employees and business partners and is based on our common values. It is only by letting these values guide us in everything we do, and treating each other and our business partners with respect,

Herewith I confirm that I received the Code of Conduct Booklet.

Employee signature/Date

Print Name